

R The Platinum 900 and 2040 Cartridge Filter Housings

Ultra high capacity filtration system provides maximum dirt holding capacity—eliminating maintenance

End the high cost of element change-out with the Platinum 900 and 2040 cartridge filter system. Imagine changing a filter element only once or twice a year, instead of changing several cartridges on a weekly or daily basis!

Standard Features

- Housings available in carbon steel, 304 or 316 stainless steel.
- Pressure rating 150 psi
- Clean and dirty/gauge port connections
- O-ring seals: Buna, Ethylene Propylene and Viton®
- Covers are o-ring sealed and easy to remove
- ASME code stamp (optional)
- Flange connection sizes from 3-inch through 10-inch
- Cable-hoist assembly for quick and easy removal of element is standard on Model 18 (optional on other models)

A single cartridge system has the life of hundreds of standard wound or 50 pleated cartridges. This reduces maintenance and cartridge use, labor, inventory, worker exposure, and disposal costs.

Flow rates and contaminant holding capacities vary depending on micron size. A single cartridge element can hold up to 400 pounds of contaminant and flows to 600 gallons per minute. Elements are 13- or 20-inch diameter and 40-inches long.

The 900 Series filter housings contain one, three, four, seven, or eight cartridges. The 2040 Series is available a single cartridge.

By using the cable-hoist assembly change-out is completed in minutes. The element shipping container allows for easy handling and disposal.



Extra large cartridges hold more contaminate.

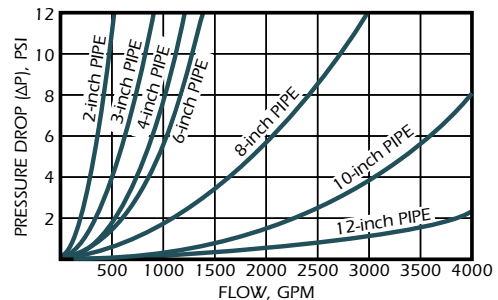

* Based on housing only. Fluid viscosity, filter cartridge used, and expected dirt loading should be considered when sizing a filter.

Viscosity Factors

	CPS NUMBER								
$1/(H_2O)$	50	100	200	400	600	800	1000	2000	
	.65	.85	1.00	1.10	1.20	1.40	1.50	1.60	1.80

For more detailed design information and how to order the 900 and 2040 Series cartridge element see page 182.

How To Order

Build an ordering code as shown in the example

Example: **SLP - 18140 - 4F - 1- 150 - S - B - 900 - C**

HOUSING STYLE

Standard Low Profile = **SLP**

MODEL NUMBER

Model 18, 1 Element = **18140**

Model 22, 1 Element = **22140**

Model 30, 3 Elements = **30340**

Model 36, 4 Elements = **36440**

Model 42, 7 Elements = **42740**

Model 48, 8 Elements = **48840**

PIPE SIZE, FLANGED

Model 18 = **2F or 3F**

Model 30 = **4F or 6F**

Model 36 = **6F or 8F**

Model 42 = **8F or 10F**

Model 48 = **8F or 10F**

OUTLET STYLE

Side In/Side Out = **1**

PRESSURE RATING

150 PSI = **150**

HOUSING MATERIAL

304 Stainless Steel = **S**

Carbon Steel = **C**

316 Stainless Steel = **S316**

COVER GASKET

Buna = **B**

Ethylene Propylene = **E**

Viton® Fluorelastomer = **V**

Teflon® Encapsulated Viton® = **TEV**

ELEMENT SERIES

= **900**

= **2040** (22140 element only)

ASME CODE OPTION

ASME Code Stamp = **C**

MODEL NUMBER & Dim. A	Pipe Sizes B	Leg Bolt Circle Dia.	C	D	E	F	G	H
18	2	16.0	22.2	53.4	72.2	8.0	14.0	101.8
	3		21.6	53.8	72.7	9.0	15.0	102.3
22	4	14.6	24.0	58.9	76.9	6.0	17.25	107.6
	6		28.8	56.2	76.6	10.0	23.0	
30	4	28.0	29.9	56.2	76.6	9.0	22.5	
	6		28.8	56.2	76.6	10.0	23.0	
36	6	34.0	28.7	57.7	79.5	10.5	26.0	
	8		27.3	57.7	79.5	11.5	27.0	
42	8	40.0	26.3	60.0	83.3	11.5	29.5	
	10		25.2	59.9	83.2	12.5	30.0	
48	8	46.0	29.2	61.2	86.7	11.5	32.5	
	10		28.1	61.1	86.6	12.5	33.0	

Dimensions (IN)

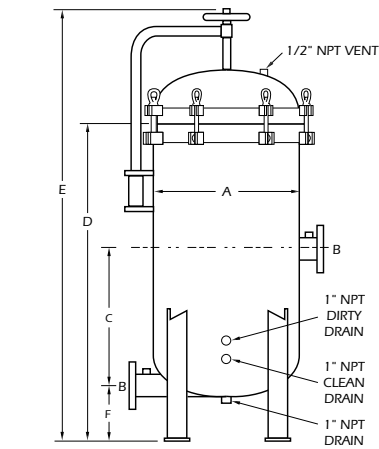
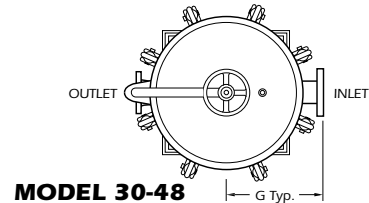
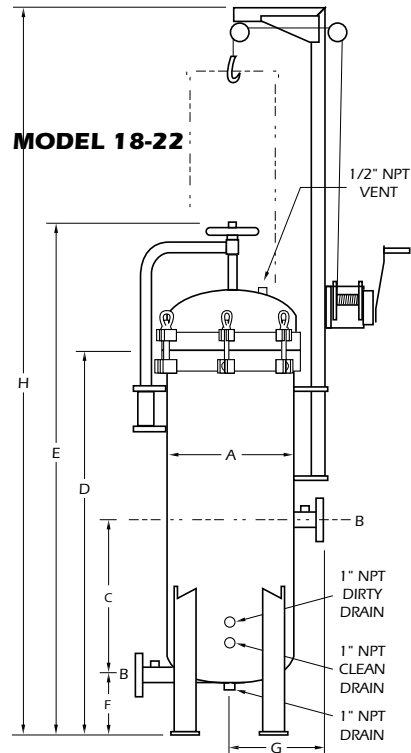

Dimensions are reference only and should not be used for hard plumbing. Consult factory for certified drawings.