

**ENGINEERING STANDARDS**

Rosedale Products, Inc.  
3730 West Liberty Road  
Ann Arbor, MI 48103

Service Bulletin  
7\_2\_9 Model 4 Ind 200.wpd  
n:\iom\



Issue Date: 04Dec95  
Revision: A  
Revision Date: 30MAY2003

Specification No.  
**7.2.9**  
PAGE: 1 of 9

**INSTALLATION, OPERATION, & MAINTENANCE MANUAL**

# INSTALLATION, OPERATION AND MAINTENANCE MANUAL

ROSEDALE PRODUCTS, INC.



MODEL 4, 200 psig COVER STYLE

INDICATOR FILTER UNIT

## Table of Contents

I.	Installation .....	2
A.	Electrical Switch Wiring .....	3
II.	Operation .....	3
III.	Spare Parts List .....	5
IV.	Spare Parts Diagram .....	6
V.	Indicator Box Spare Parts List .....	7
VI.	Indicator Box Spare Parts Diagram .....	8

## ENGINEERING STANDARDS

Rosedale Products, Inc.  
3730 West Liberty Road  
Ann Arbor, MI 48103

Service Bulletin  
7\_2\_9 Model 4 Ind 200.wpd  
n:\iom\



Issue Date: 04Dec95  
Revision: A  
Revision Date: 30MAY2003

Specification No.  
**7.2.9**  
PAGE: 2 of 9

### INSTALLATION, OPERATION, & MAINTENANCE MANUAL

#### I. Installation

Please remove all shipping and crating materials carefully. Be sure to remove the plugs from the inlet and outlet openings. Dispose of all crating materials safely.

The Model 4 Filter unit is capable of having several different piping variations based upon the outlet style of your unit. The inlet service line should be connected to the inlet flange or NPT coupling located near the top of the unit (above the basket level).

The outlet service line should be connected to the outlet flange or coupling, located near the middle or bottom of the unit depending upon the style of your unit (below basket level).

There is one 1/4" NPT port on the cover of the Model 4 Filter unit. This port can remain plugged or used for pressure gauges or special fittings as your application requires.

Some installations require electrical grounding of all equipment, be sure to provide adequate grounding where necessary.

After completing installation be sure to double check connections for integrity. Your Model 4 Filter unit has been factory pressure tested leak free, therefore, any seepage problems usually occur from improper installation connections.

You are now ready to install the filter basket and bag. Remove cover by loosening the T-bolt clamp sufficiently to allow removal of the clamp assembly, lift cover to remove.

Place the basket into the filter housing, make sure the basket bottom has been seated over the spring (see Spare Parts Diagram).

Insert bag into the bag basket making sure filter bag ring is firmly seated on the I.D. of the housing. For best results, be sure filter bag is installed fully extended to the bottom of the basket.

Before replacing cover assembly, inspect cover seal gasket (replacing as necessary). Replace cover and securely tighten T-bolt clamp closure to ensure a leak proof seal between cover and housing body.

## ENGINEERING STANDARDS

Rosedale Products, Inc.  
3730 West Liberty Road  
Ann Arbor, MI 48103

Service Bulletin  
7\_2\_9 Model 4 Ind 200.wpd  
n:\iom\



Issue Date: 04Dec95  
Revision: A  
Revision Date: 30MAY2003

Specification No.  
**7.2.9**  
PAGE: 3 of 9

### INSTALLATION, OPERATION, & MAINTENANCE MANUAL

#### A. Electrical Switch Wiring

The following diagram displays the appropriate connections for electrical wiring.

**WARNING: Instrument to AC power lines constitute a potential electric shock to users. Make certain that the branch circuit is disconnected from the power supply before touching anything inside the control box.**

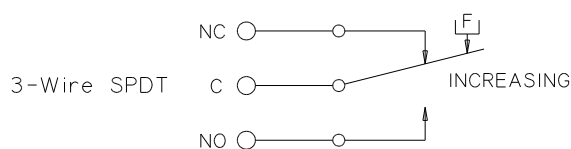

Your Rosedale Model 4 is now ready for operation!

#### II. Operation

##### Filter System Start-Up Procedure:

Prior to turning on the flow to the inlet service, please make the following checks:

1. Check inside filter unit to be sure basket and filter bag are in housing and do not require cleaning or replacement. If necessary install a clean filter basket and bag.
2. Check that filter unit cover is securely fastened to housing. You are now ready to open the flow to the inlet service line. Slowly open the inlet service line approximately 25% of normal operational flow (open slowly as not to displace filter bag inside the housing). After filter unit is pressurized and vented, slowly open outlet service line unit valve until completely open. Complete opening of inlet service line until desired flow rate is reached.

Once the desired service flow has been established, the filter will operate efficiently until dirty. However, under no circumstances should more than *15 PSI Differential Pressure* through the filter be obtained. Operating the filter unit with a high differential may cause filter bags to rupture and/or cause damage to filter system and downstream equipment.

Your Rosedale Filter has been supplied with a factory installed indicator box which allows for visual and electrical warnings as a means of determining whether or not the filter media needs cleaning or replacement. Inside the window on the indicator box will be a green and red scale (green for clean and red for dirty) with a pointer resting on a stop pin. On the interior of the housing, opposite the indicator box is the arm for indicating. The arm will rest on the bottom side of the basket flange. As fluid flows into the housing and causes the bag to become dirty the basket will force the arm down and the indicator pointer will move from the clean (green) to dirty (red) side of the scale. The spring on the bottom of the housing is designed to allow only 15 PSI differential pressure through the housing. If the bag is not changed after the pointer has reached the filter dirty area of the scale, the basket will stop when it has reached its designed travel limit. This keeps the basket from damaging the arm on the interior of the housing.

## ENGINEERING STANDARDS

Rosedale Products, Inc.  
3730 West Liberty Road  
Ann Arbor, MI 48103

Service Bulletin  
7\_2\_9 Model 4 Ind 200.wpd  
n:\iom\



Issue Date: 04Dec95  
Revision: A  
Revision Date: 30MAY2003

Specification No.  
**7.2.9**  
PAGE: 4 of 9

### INSTALLATION, OPERATION, & MAINTENANCE MANUAL

When it becomes necessary to clean or replace filter media, follow the procedure outlined below:

1. First close the flow from the inlet service line.
2. Close the flow to the outlet service line. (In some applications closing flow to outlet is not required.)
3. Relieve the pressure from the filter unit.

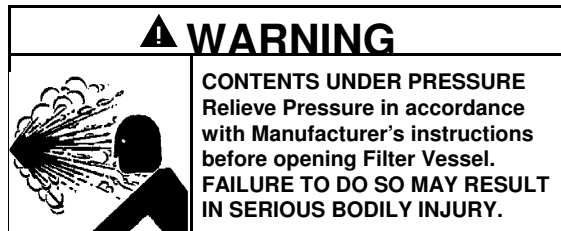

4. Drain housing sufficiently to access filter basket.
5. Remove cover by loosening the T-bolt clamp sufficiently to allow removal of the clamp assembly, lift cover to remove.
6. Remove filter basket and clean thoroughly, remove the filter bag and throw away. (Cleaning and reusing the filter bag is not recommended.)
7. Remove debris and sludge from inside the inlet portion of housing to avoid interference with cover seal or flow of fluid being filtered.
8. Install clean filter basket and filter bag. **Use caution not to damage indicating arm on interior of housing when replacing basket.** Place the basket into the filter housing, make sure the basket bottom has been seated over the spring (see Spare Parts Diagram). Insert bag into the bag basket making sure filter bag ring is firmly seated on the I.D. of the housing. For best results, be sure filter bag is installed fully extended to the bottom of the basket.
9. Inspect cover gasket for cuts or other signs of failure and make sure it is properly seated.
10. Reposition cover onto housing, install T-bolt clamp and securely tighten to ensure a leak proof seal between the cover & housing body.

Your Rosedale Model 4 Filter unit is now ready for operation. Refer to filter system start-up procedure.

# ENGINEERING STANDARDS

Rosedale Products, Inc.  
3730 West Liberty Road  
Ann Arbor, MI 48103

Service Bulletin  
7\_2\_9 Model 4 Ind 200.wpd  
n:\iom\



Issue Date: 04Dec95  
Revision: A  
Revision Date: 30MAY2003

Specification No.  
**7.2.9**  
PAGE: 5 of 9

## INSTALLATION, OPERATION, & MAINTENANCE MANUAL

### III. Spare Parts List

Your Rosedale Model 4 Filter unit will give you many years of reliable service provided periodic inspections are made of various components and replacement of worn parts are made promptly. The following is meant to be a recommended spare parts list, these parts are illustrated on the following page.

SPARE PARTS LIST			
Balloon	Description	Part Number	Time-Frame
1	Cover	4C200-*	as needed
2	Cover Seal	4200CG-*	as needed
3	Indicator Box	C11232.12.**	as needed
4	T-Bolt	4T-Bolt	as needed
5	T-Handle	4T-Handle	as needed
6	Cover Clamp	4CC200	as needed
7	Filter Bag	(See Order)	as needed
8	Filter Basket	B11232.43.1	as needed
9	Spring	5I-6052	as needed

\* Select Material Designation:

C=Carbon Steel  
S=304 Stainless Steel  
S316=316 Stainless Steel  
HC22=Hastelloy C-22

B=Buna N  
E=Ethylene Propylene  
V=Viton  
TEV=Teflon Encapsulated Viton  
TSW=Teflon Solid White

\*\* Indicator Box Selection:

.1=for Stainless Steel Housing  
.2=for Carbon Steel Housing

# ENGINEERING STANDARDS

Rosedale Products, Inc.  
3730 West Liberty Road  
Ann Arbor, MI 48103

Service Bulletin  
7\_2\_9 Model 4 Ind 200.wpd  
n:\iom\



Issue Date: 04Dec95  
Revision: A  
Revision Date: 30MAY2003

Specification No.  
**7.2.9**  
PAGE: 6 of 9

## INSTALLATION, OPERATION, & MAINTENANCE MANUAL

### IV. Spare Parts Diagram

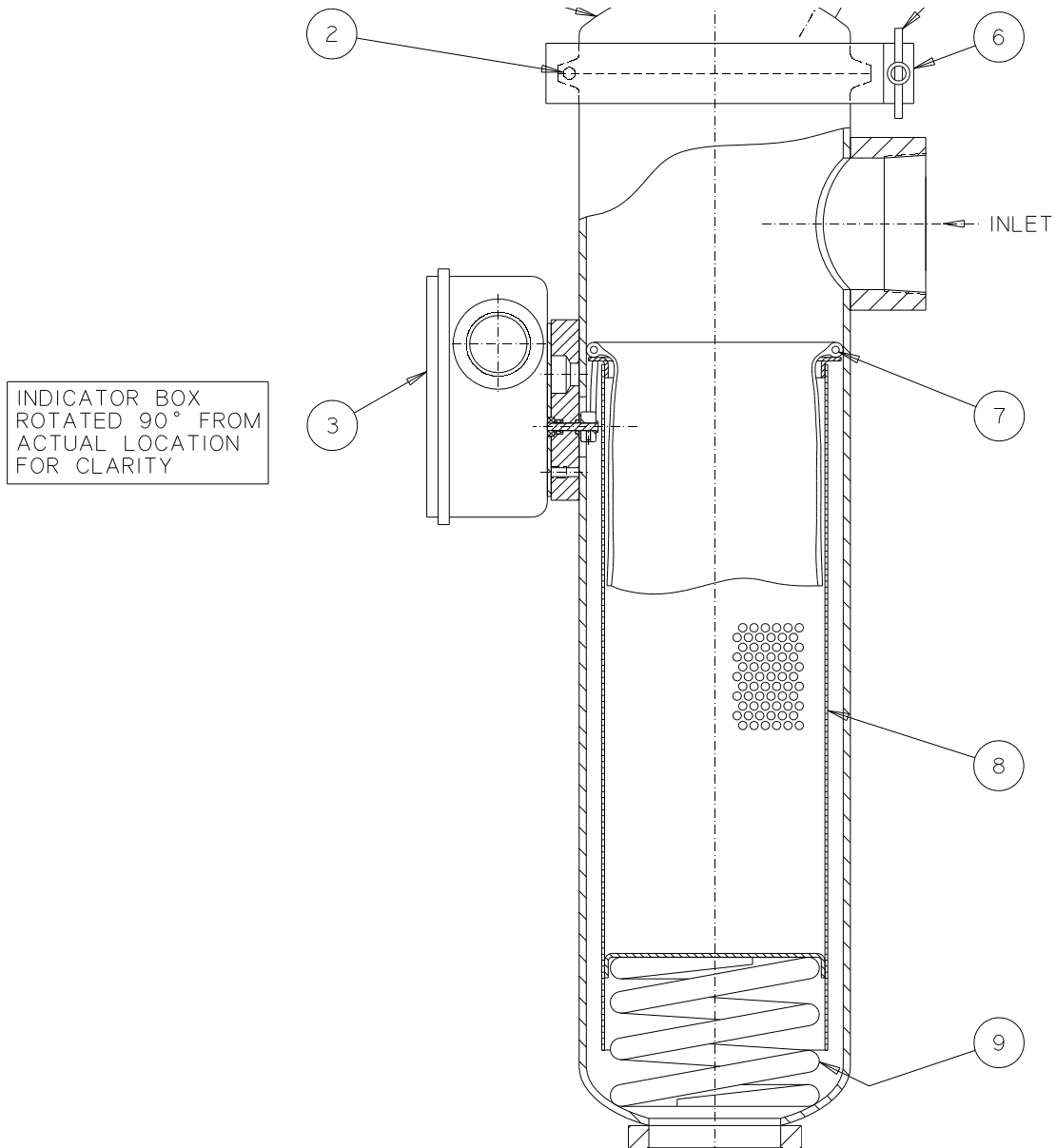

## ENGINEERING STANDARDS

Rosedale Products, Inc.  
3730 West Liberty Road  
Ann Arbor, MI 48103

Service Bulletin  
7\_2\_9 Model 4 Ind 200.wpd  
n:\iom\



Issue Date: 04Dec95  
Revision: A  
Revision Date: 30MAY2003

Specification No.  
**7.2.9**  
PAGE: 7 of 9

### INSTALLATION, OPERATION, & MAINTENANCE MANUAL

#### V. Indicator Box Spare Parts List

INDICATOR BOX SPARE PARTS LIST			
Balloon	Description	Part Number	Time-Frame
1	Name Plate Screw	5I-6070	as needed
2	Name Plate	B11232.52.1	as needed
3	Control Box Screw	5I-6073	as needed
4	Pointer Screw	5I-6074	as needed
5	Lockwasher	5I-6077	as needed
6	Indicator Pointer	5I-6075	as needed
7	Cam	5I-6082	as needed
8	Dial	5I-6083	as needed
9	Set Screw	5-0567	as needed
10	Spring	5I-6084	as needed
11	Spring Retainer	5I-6087	as needed
12	S.H.C.S.	5I-6065	as needed
13	Drive Screw	5I-6120	as needed
14	Scale Finished	A11232.51.1	as needed
15	S.H.C.S.	5I-6096	as needed
16	Switch Retainer Nut	5I-6090	as needed
17	Switch 3-Wire SPDT	5I-6093	as needed
18	Switch Spacer	5I-6115	as needed
19	Grounding Lug	5I-6121	as needed
20	Control Box	5I-6100	as needed
21	Box Gasket	5I-6067	as needed
22	Bearing 1/8"	5I-6053	as needed
23	Glide Ring 1/8"	5I-6054	as needed
24	Shaft Seal	5I-6068	as needed

# ENGINEERING STANDARDS

Rosedale Products, Inc.  
3730 West Liberty Road  
Ann Arbor, MI 48103

Service Bulletin  
7\_2\_9 Model 4 Ind 200.wpd  
n:\iom\



Issue Date: 04Dec95  
Revision: A  
Revision Date: 30MAY2003

Specification No.  
**7.2.9**  
PAGE: 8 of 9

## INSTALLATION, OPERATION, & MAINTENANCE MANUAL

25	Roll Pin	5I-6107	as needed
26	Mounting Pad	5I-6064	as needed
27	Breather Vent	5I-6111	as needed
28	Washer 1/8"	5I-6066	as needed
29	Dowel Pin	5I-6132	as needed
30	Arm	5I-6041	as needed
31	Set Screw	5I-6122	as needed
32	Shaft	5I-6039	as needed
33	Shaft Seal	5I-6136	as needed

### VI. Indicator Box Spare Parts Diagram

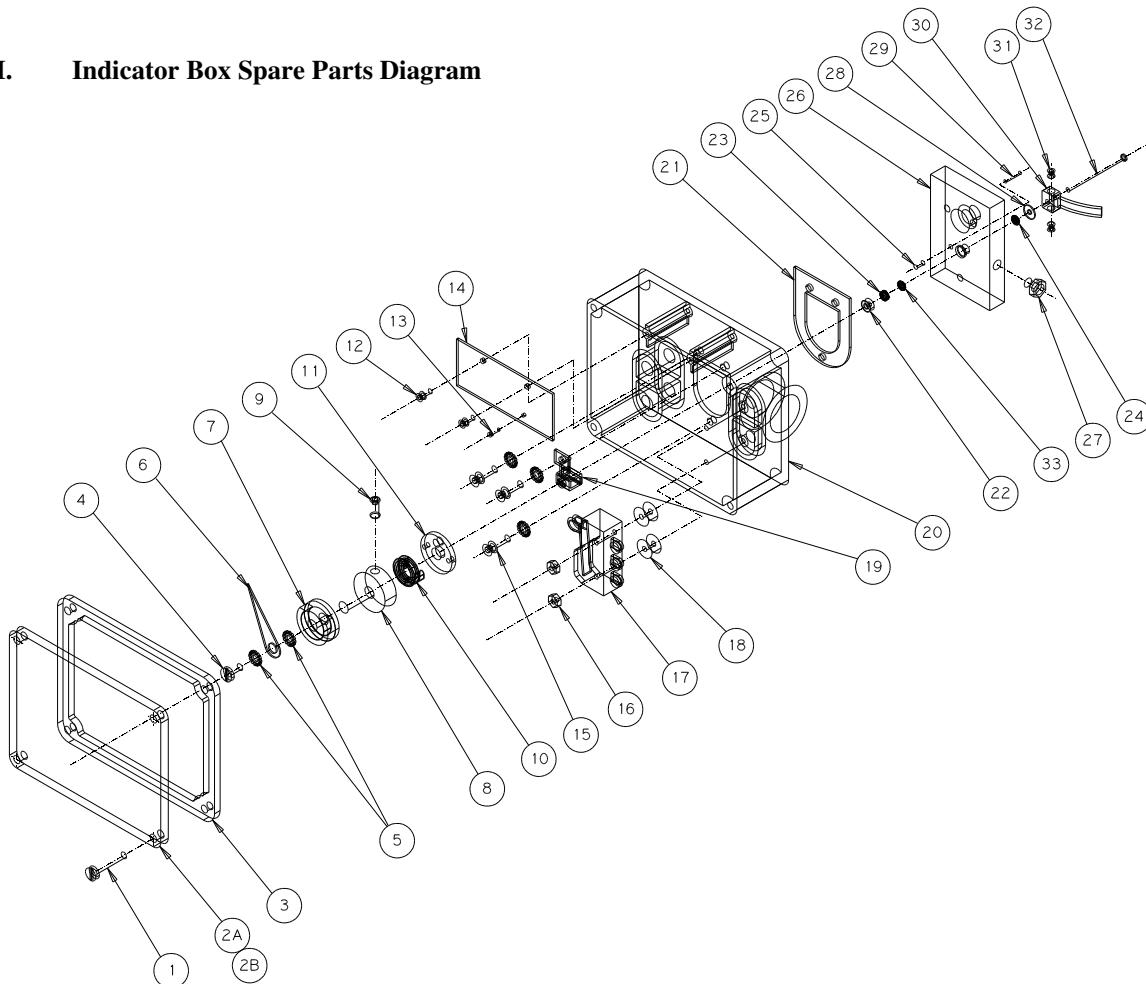



## ENGINEERING STANDARDS

Rosedale Products, Inc.  
3730 West Liberty Road  
Ann Arbor, MI 48103

Service Bulletin  
7\_2\_9 Model 4 Ind 200.wpd  
n:\iom\



Issue Date: 04Dec95  
Revision: A  
Revision Date: 30MAY2003

Specification No.  
**7.2.9**  
PAGE: 9 of 9

## INSTALLATION, OPERATION, & MAINTENANCE MANUAL

### Important Notice

**Warranty:** In the event any Rosedale Products, Inc. filtration product is found to be defective in material, workmanship, or not in conformance with any express warranty for a specific purpose, Rosedale's only obligation and your exclusive remedy, shall be to repair, replace or refund the purchase price of such parts or products upon timely notification thereof and substantiation that the product has been stored, maintained and used in accordance with Rosedale's written instructions.

**EXCLUSIONS TO WARRANTY:** THIS WARRANTY IS EXCLUSIVE AND IS IN LIEU OF ANY IMPLIED WARRANTY OF MERCHANTABILITY, FITNESS FOR A PARTICULAR PURPOSE OR OTHER WARRANTY OF QUALITY, EXCEPT OF TITLE AND AGAINST PATENT INFRINGEMENT.

**LIMITATION OF LIABILITY:** Except as provided above, Rosedale shall not be liable or responsible for any loss or damage, whether direct, indirect, incidental, special or consequential, arising out of sale, use or misuse of Rosedale filtration products, or the user's inability to use such products.

THE REMEDIES SET FORTH HEREIN ARE EXCLUSIVE.

**Rosedale Products, Inc.**  
3730 West Liberty Road  
Ann Arbor, MI 48103 USA  
313-665-8201  
800-821-5373  
Fax. 313-665-2214  
Filters@mcimail.com  
<http://www.webcom.com/~filters/>