

R Model 82 Dual Capacity Bag Filter And Basket Strainer

Extra capacity at higher flow rates!

Rosedale dual capacity housings can serve as either basket strainers or bag filters. Covers are easily removed, without tools, and the basket or bag is quickly and easily cleaned or replaced. Rosedale's bag-sized pleated cartridges will provide even greater dirt-holding capacity (see pages 81-84).

Low price, greater dirt holding capacity, and higher flow rates make the Model 82 a very cost-efficient choice!

Features

- Low pressure drops
- Permanently-piped housings
- Covers are O-ring sealed
- Carbon steel or stainless steel (304 or 316) housings
- Housings are electropolished to resist adhesion of dirt or scale
- Adjustable-height legs
- For flow rates to 440 gpm
- ASME code stamp available
- Large-area, heavy-duty baskets
- Dual stage straining/filtering

Options

- Higher pressure ratings
- Extra-length legs
- Heat jacketing
- Liquid displacers for easier servicing

Basket Data (each basket, two baskets total)

Depth inches (nominal)	Diameter (inches)	Surface Area (sq. ft.)	Volume (cu. in.)	Bag Size No.
15	6.7	2.3	500	1
30	6.7	4.4	1000	2



How To Order

Build an ordering code as shown in the example

	Housing	Options
Example:	82- 30- 4F- 1 -150- C - B - S - BM- 200 -D - C	
MODEL 82 = 82		
HOUSING SIZE		
15 inch = 15		
30 inch = 30		
PIPE SIZE, NPT & FLANGED		
2-in. 150 or 300-lb ANSI flange* = 2F		
3-in. 150 or 300-lb ANSI flange* = 3F		
4-in. 150 or 300-lb ANSI flange* = 4F		
6-in. 150 or 300-lb ANSI flange* = 6F		
*Dependent on required pressure rating		
OUTLET STYLE		
Side = 1		
PRESSURE RATING¹		
150 psi (flanged) = 150		
300 psi (flanged) = 300		
HOUSING MATERIAL		
Carbon steel = C		
304 stainless steel = S		
316 stainless steel = S316		
COVER SEAL		
Buna N = B		
Ethylene Propylene = E		
Viton® Fluoroelastomer = V		
Teflon® Encapsulated Viton® = TEV		
Teflon® (solid white) (6 Bolt Cover) = TSW		
BASKET SEAL		
Seal (required) = S		
BASKET TYPE		
Filter bag basket ² = PB		
Strainer basket = P		
Filter bag basket, mesh lined ² = BM		
Strainer basket, mesh lined = M		
Filter bag basket, heavy wire mesh = HWM		
BASKET, MEDIA SIZE , no symbol if type B basket was selected		
Type P perforation diameters 1/4, 3/16, 9/64, 3/32, 1/16		
Type M and BM mesh sizes 20, 30, 40, 50, 60, 70, 80, 100, 150, 200 = 200		
DISPLACER		
Displacer = D		
ASME CODE STAMP		
Code = C		

- Higher pressures are available, consult factory.
- Filter bags are specified separately. See pages 73-80.
- Flanges provided with the housing match the pressure rating of the vessel. Housings rated 150 psi have 150 class flanges. Housings rated 300 psi have 300 class flanges.

Dimensions (IN)

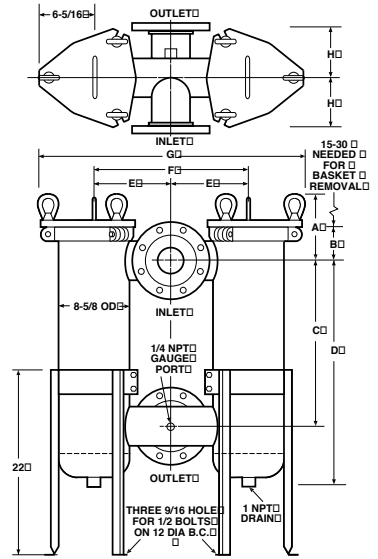

Pipe Size	2	3	4	6
A	6-5/8	7-1/2	7-1/2	9
B	2-7/8	3-3/4	3-3/4	5-1/4
C (15 in)	14-1/2	14-1/2	14-1/2	14-1/2
(30 in)	29-1/2	29-1/2	29-1/2	29-1/2
D (15 in)	21-3/16	22-3/32	22-3/32	23-9/16
(30 in)	36-3/16	37-3/32	37-3/32	38-9/16
E	8	8	9	9
F	16	16	18	18
G	28-9/16	28-9/16	30-9/16	30-9/16
H	4-1/2	5-1/2	6-1/2	8

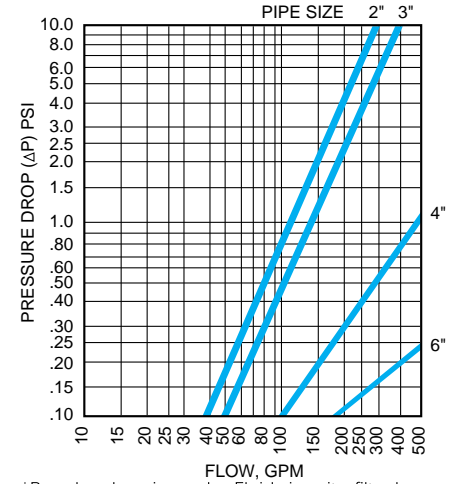

*Based on housing only. Fluid viscosity, filter bag used, and expected dirt loading should be considered when sizing a filter.

Dimensions are reference only and should not be used for hard plumbing. Consult factory for certified drawings.