

R Model OT Bag Filter Housing

Guarantees a 360° positive seal
for flows to 100 gpm*

Performance

The Model OT filter provides optimum filtration performance when combined with our high capacity filter bags. Our unique design ensures a 360-degree positive seal and media compression, eliminating the potential for bypass. Unfiltered liquid and debris does not accumulate above the filter bag and contaminate the clean fluid area during change-out. Fluid passes through the bag from inside to outside. The Rosedale Model OT filter ensures an even flow into the filter bag where contaminate is contained for easy disposal.

Construction

The Model OT housing is a durable, high capacity filter with an uncompromising welded construction to meet ASME Section VIII Code requirements. The cover is hinged and fastened with swing bolts for quick access and easy bag change-out. They have a high quality electropolished finish to resist adhesion of dirt and scale, making routine maintenance fast and simple.

Model OT filters are available in two sizes with flanged or threaded connections. Customize with several options, including gauges and switches. A wide range of filter bags or cartridges (rated 0.5 μ absolute to 100 μ nominal) with various surface areas can be utilized in this housing.

Features

- Accepts all major competitive brands of bags
- Permanently piped housings are opened without special tools
- Carbon or stainless steel housings
- Covers are O-ring sealed
- All sealing surfaces are blancher ground
- O-ring seals: Buna N, EPR, Viton® and Teflon®
- 150 psi rated housing
- ASME Code Stamp available
- Heavy-duty basket with over 50% open area
- Bag/Basket surface area is 2.3 square feet (number 1 size), or 4.4 square feet (number 2 size)
- 2-inch inlet and outlet
- 1/4-inch NPT gauge ports and vent connection
- 1/2-inch NPT drain connection
- Adjustable-height tripod leg assembly



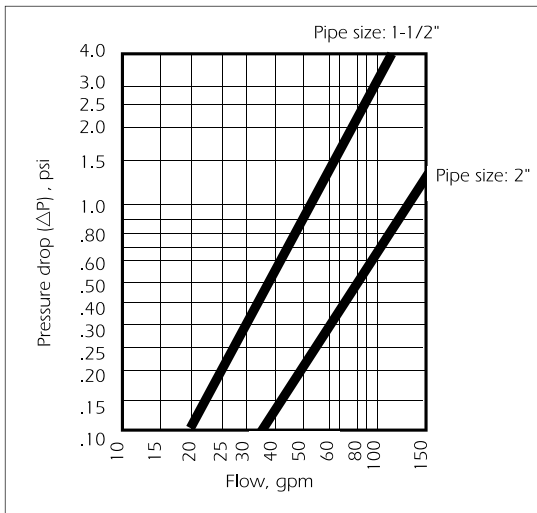

*Based on housing only. Fluid viscosity, filter bag used, and expected dirt loading should be considered when sizing a filter.

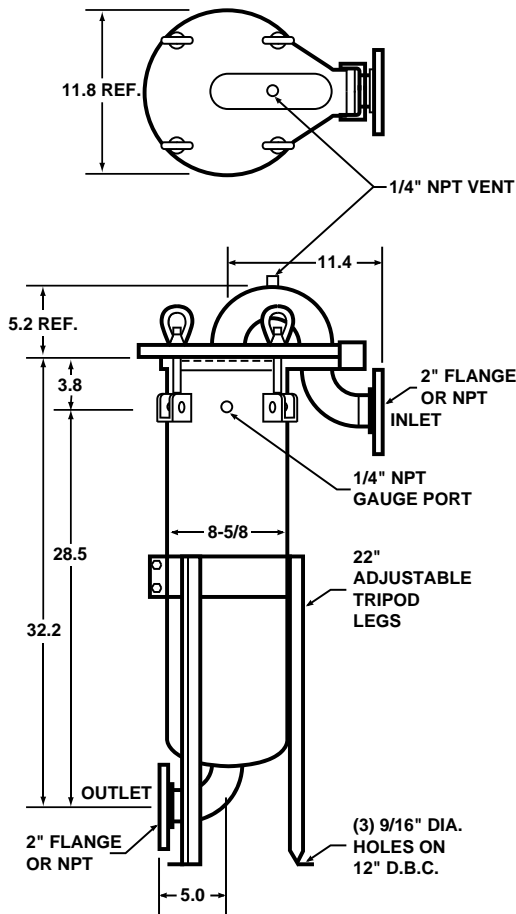

How To Order

Build an ordering code as shown in the example.

| | Housing | Options |
|-------------------------|---|---------|
| Example : | OT8-30 - 2P - 3 - 150 - C - B - PB - C | |
| MODEL | OT8 | |
| BASKET SIZE | 15-inch = 15 30-inch = 30 | |
| PIPE SIZE | 2-inch female NPT = 2P 2-inch 150 class ANSI flange = 2F | |
| OUTLET STYLE | Bottom = 1 Side = 2 Bottom elbow = 3 Side out, same side (low profile) = 4 | |
| PRESSURE RATING | 150 psi = 150 | |
| HOUSING MATERIAL | Carbon steel = C 304 Stainless steel = S 316 Stainless steel = S316 | |
| COVER SEAL | Buna N = B Ethylene propylene = E Viton® Fluoroelastomer = V Teflon Encapsulated Viton = TEV | |
| BASKET TYPE | Filter bag basket = PB | |
| ASME CODE STAMP | Code = C | |

1. Filter bags are specified separately. See pages 73-79.
2. Weight (approximately): 100 lbs.

