

Rosedale Model HSS

SINGLE CARTRIDGE HOUSINGS FOR LIQUIDS



R O S E D A L E F I L T R A T I O N P R O D U C T S

Rosedale Model HSS

Single Cartridge Housings for Liquids

The Rosedale Model HSS single element filter housing is a three piece, all stainless steel unit ideal for general industrial service. It features a ring-nut closure for easy access to the head and cartridge sump.

The HSS is available in 10" or 20" cartridge models. Our head assembly has 1" NPT connections and is equipped with tapped mounting pads.

HSS units are rated for 150 PSI service at 200°F. Flow rates to 30 GPM are acceptable depending on cartridge selection. Buna-N gaskets are standard, while other materials are available.

Standard Features

- Simple ring closure for quick cartridge change outs
- In line fittings for easy installation
- Knife edge seal at both cartridge ends to eliminate by-pass
- Housings accept double-open-end cartridges
- Standard with mounting bracket kit

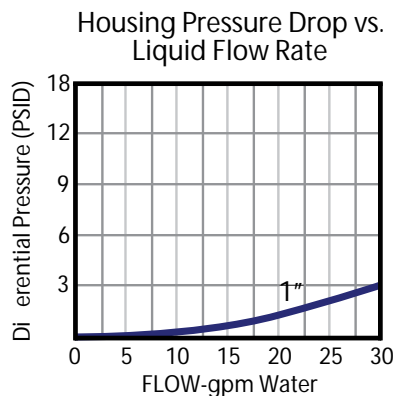

Dimensions (IN)

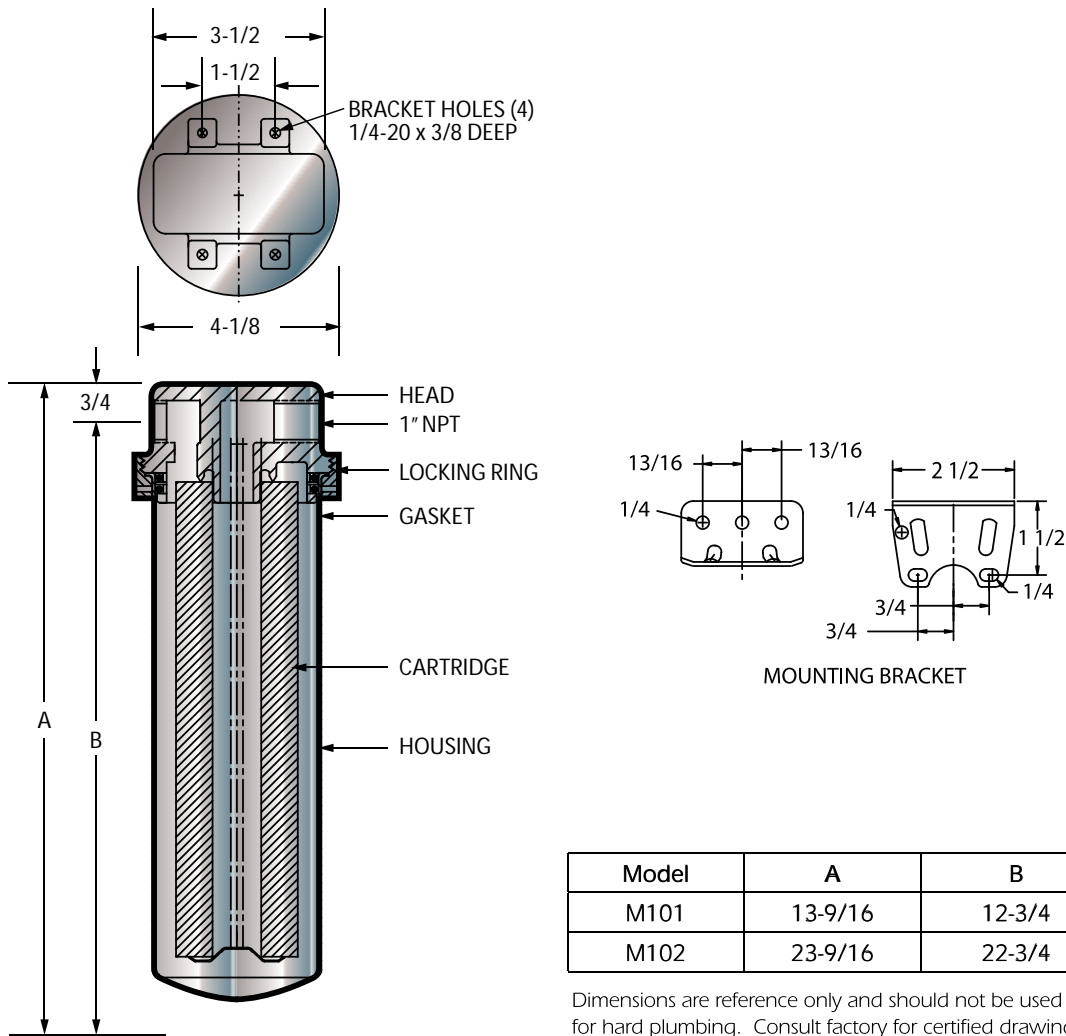

Model	A	B
M101	13-9/16	12-3/4
M102	23-9/16	22-3/4

Dimensions are reference only and should not be used for hard plumbing. Consult factory for certified drawings.

Standard Design Specifications

Model	Qty. (Length) of Cartridges	Flow Rate GPM*	Max Ctg Diameter	Approx. Ship Weight	Box Size
M101	1 (10i)	7	2 3/4i OD	6 lbs	4x5x16
M102	1 (20i)	14	2 3/4i OD	8 lbs	4x5x25

Based on 7gpm per 10i length with a 25 micron wound cartridge at 2PSID clean and a viscosity of 1 cps.
*Flow rates are guide lines only. Actual flow rates are based on fluid, viscosity, cartridge type, micron ratings and other factors.

How To Order

Build an ordering code as shown in the example

Example: **HSS - M101 - SS304 - CF51.0 NPT - V**

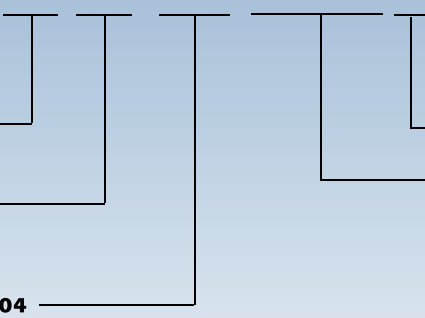
<p>MODEL Series DOE Cartridge Filter = HSS</p> <p>CARTRIDGE LENGTH 10" = M101 20" = M102</p> <p>MATERIAL 304 stainless steel = SS304</p>		<p>GASKET Blank = Buna-N E = EPR V = Viton</p> <p>CF51.0 NPT = 1" NPT</p>
---	---	--



ROSEDALE

Filtration Products, Inc.

3730 W. Liberty, Ann Arbor, Michigan 48103
 Phone: 800-821-5373 or 734-665-8201 Fax: 734-665-2214
filters@rosedaleproducts.com www.rosedaleproducts.com