

Cartridge Filter Housings

These cartridge filters offer a wide range of flow capacities and contaminant holding capabilities. The housings can accommodate from 1 to 205 cartridges around. All housings can be supplied with an ASME code stamp, if required.

Standard Features

- Low pressure drop
- Permanently piped housings are opened without special tools and without disturbing the piping
- Machined cover gasket groove provides positive O-ring sealing
- Easy to clean
- In-line inlet and outlet
- Stainless steel internals

Standard Options

- 2 outlet styles
- Carbon steel, 304 or 316 stainless steel housings
- ASME code stamp
- O-ring seals: Buna N, EPR, Viton®, Teflon®
- Accommodates 10, 20, 30 or 40-inch cartridges
- Flanged connections for 3/4 through 12-inch pipe
- V posts or threaded center posts
- Units accept DOE or 222 style cartridges

How They Work

Unfiltered fluid enters the housing and is distributed evenly around the cartridges, from outside to inside. Solids are collected on the outside for easy removal. The filtered fluid then exits through the outlet pipe.

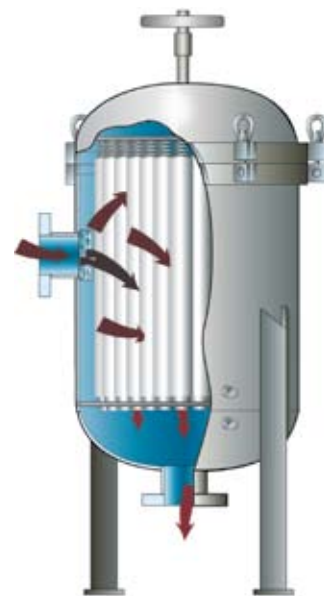
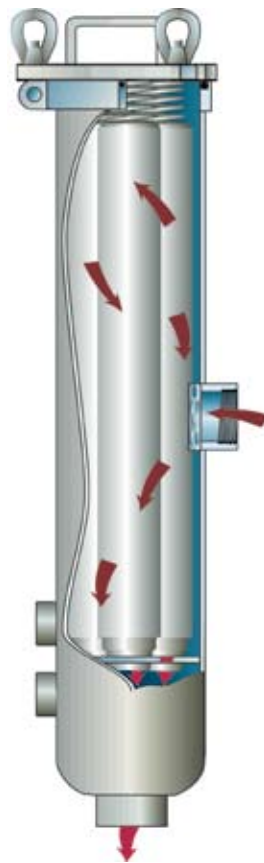

Center: Models 4, 6 and 8
Bottom Right: Models 12 thru 48

Cartridge Requirements

The following table gives the number of cartridges needed for each housing model.

Model Number and Diameter	Cartridge Lengths	Number of Cartridges	Equivalent 10-inch lengths	Available Pipe Sizes
Model 4	10-inch	1	1	3/4, 1, 1-1/4, 1-1/2, 2
	20-inch	1	2	
	30-inch	1	3	
	40-inch	1	4	
Model 6	20-inch	3	6	3/4, 1, 1-1/4, 1-1/2, 2, 3
	30-inch	3	9	
	40-inch	3	12	
Model 8	20-inch	6	12	3/4, 1, 1-1/4, 1-1/2, 2, 3
	30-inch	6	18	
	40-inch	6	24	
Model 12	20-inch	12	24	2,3,4
	30-inch	12	36	
	40-inch	12	48	
Model 16	20-inch	20	40	2,3,4
	30-inch	20	60	
	40-inch	20	80	
Model 18	20-inch	27	54	2,3,4
	30-inch	27	81	
	40-inch	27	108	
Model 22	20-inch	40	80	3,4,6
	30-inch	40	120	
	40-inch	40	160	
Model 24	20-inch	52	104	3,4,6
	30-inch	52	156	
	40-inch	52	208	
Model 30	20-inch	82	164	4,6,8
	30-inch	82	246	
	40-inch	82	328	
Model 36	20-inch	116	232	6,8,10
	30-inch	116	348	
	40-inch	116	464	
Model 42	20-inch	158	316	8,10,12
	30-inch	158	474	
	40-inch	158	632	
Model 48	20-inch	205	410	8,10,12
	30-inch	205	615	
	40-inch	205	820	

Determining Housing Pressure Drop Only

The pressure drops shown on the graph are reliable for all cartridge housings. The pressure drop of any housing is governed by the size of the inlet and outlet, not the vessel itself.

- Using desired pipe size and approximate flow rate, determine the basic pressure drop from the graph.
- Multiply the pressure drop obtained in step 1 by the viscosity correction factor found in the accompanying table.
- You now have the pressure drop for an empty cartridge housing.
- The user selected cartridge pressure drop must then be added to the housing pressure.
- To calculate pressure drop through cartridges, see page 166.

Viscosity Factors

	CPS NUMBER							
$1(H_2O)$	50	100	200	400	600	800	1000	2000
.65	.85	1.00	1.10	1.20	1.40	1.50	1.60	1.80

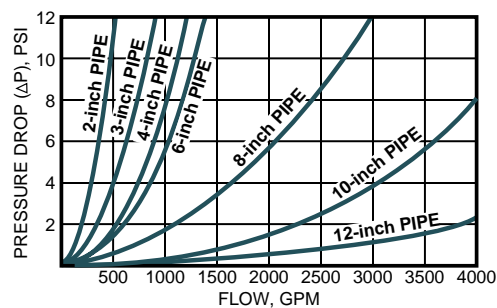

*Based on housing only. Fluid viscosity, filter cartridge used, and expected dirt loading should be considered when sizing a filter.

R **Dimensions for Models 4, 6, and 8 (IN)**

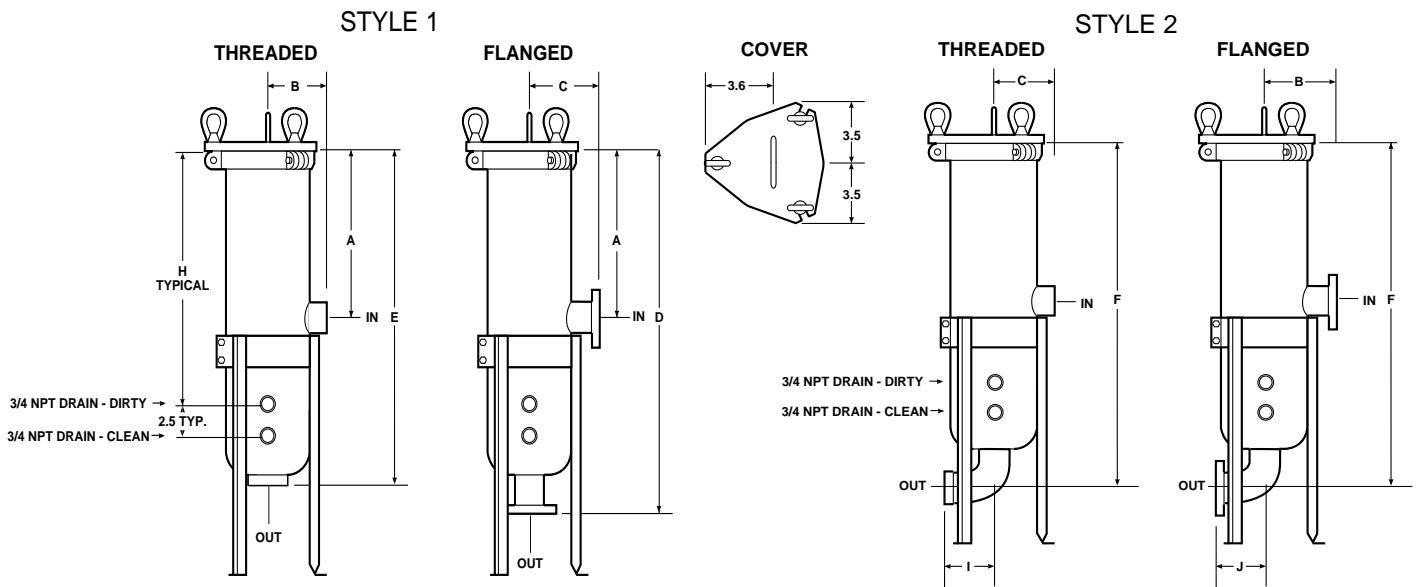

Model No.	Pipe Size	A	B	C	D	E	F	H	I	J
4110	3/4	6.0	5.0	3.5	20.0	18.6	18.9	11.8	1.9	4.0
	1	6.0	5.0	3.5	20.0	18.8	19.3	11.8	2.5	4.0
	1-1/4	6.0	5.0	3.5	20.0	18.8	19.7	11.8	2.9	4.0
	1-1/2	6.0	5.0	3.5	20.0	18.8	20.1	11.8	3.3	4.0
	2	6.0	5.0	3.5	20.0	18.7	20.8	11.8	4.0	5.0
4120	3/4	11.0	5.0	3.5	30.0	28.6	28.9	21.8	1.9	4.0
	1	11.0	5.0	3.5	30.0	28.8	29.3	21.8	2.5	4.0
	1-1/4	11.0	5.0	3.5	30.0	28.8	29.7	21.8	2.9	4.0
	1-1/2	11.0	5.0	3.5	30.0	28.8	30.1	21.8	3.3	4.0
	2	11.0	5.0	3.5	30.0	28.7	30.8	21.8	4.0	5.0
4130	3/4	16.0	5.0	3.5	40.0	38.6	38.9	31.8	1.9	4.0
	1	16.0	5.0	3.5	40.0	38.8	39.3	31.8	2.5	4.0
	1-1/4	16.0	5.0	3.5	40.0	38.8	39.7	31.8	2.9	4.0
	1-1/2	16.0	5.0	3.5	40.0	38.8	40.1	31.8	3.3	4.0
	2	16.0	5.0	3.5	40.0	38.7	40.8	31.8	4.0	5.0
4140	3/4	21.0	5.0	3.5	50.0	48.6	48.9	41.8	1.9	4.0
	1	21.0	5.0	3.5	50.0	48.8	49.3	41.8	2.5	4.0
	1-1/4	21.0	5.0	3.5	50.0	48.8	49.7	41.8	2.9	4.0
	1-1/2	21.0	5.0	3.5	50.0	48.8	50.1	41.8	3.3	4.0
	2	21.0	5.0	3.5	50.0	48.7	50.8	41.8	4.0	5.0

Dimensions are reference only and should not be used for hard plumbing. Consult factory for certified drawings.



Dimensions for Models 4, 6, and 8 (IN) Cont.

Model No.	Pipe Size	A	B	C	D	E	F	H	I	J
6310	3/4	6.0	6.0	4.0	21.0	18.7	18.9	11.8	1.9	5.0
	1	6.0	6.0	4.3	21.0	18.8	19.3	11.8	2.5	5.0
	1-1/4	6.0	6.0	4.3	21.0	18.8	19.7	11.8	2.9	5.0
	1-1/2	6.0	6.0	4.3	21.0	18.8	20.1	11.8	3.3	5.0
	2	6.0	6.0	4.3	21.88	18.8	20.8	11.8	4.0	5.0
	3	6.0	6.0	4.3	21.88	19.1	22.1	11.8	6.1	7.3
6320	3/4	11.0	6.0	4.0	31.0	28.7	28.9	21.8	1.9	5.0
	1	11.0	6.0	4.3	31.0	28.8	29.3	21.8	2.5	5.0
	1-1/4	11.0	6.0	4.3	31.0	28.8	29.7	21.8	2.9	5.0
	1-1/2	11.0	6.0	4.3	31.0	28.8	30.1	21.8	3.3	5.0
	2	11.0	6.0	4.3	31.88	28.7	30.8	21.8	4.0	5.0
	3	11.0	6.0	4.3	31.88	29.1	32.1	21.8	6.1	7.3
6330	3/4	16.0	6.0	4.0	41.0	38.7	38.9	31.8	1.9	5.0
	1	16.0	6.0	4.3	41.0	38.8	39.3	31.8	2.5	5.0
	1-1/4	16.0	6.0	4.3	41.0	38.8	39.7	31.8	2.9	5.0
	1-1/2	16.0	6.0	4.3	41.0	38.8	40.1	31.8	3.3	5.0
	2	16.0	6.0	4.3	41.88	38.8	40.8	31.8	4.0	5.0
	3	16.0	6.0	4.3	41.88	39.1	42.1	31.8	6.1	7.3
6340	3/4	21.0	6.0	4.0	51.0	48.7	48.9	41.8	1.9	5.0
	1	21.0	6.0	4.3	51.0	48.8	49.3	41.8	2.5	5.0
	1-1/4	21.0	6.0	4.3	51.0	48.8	49.7	41.8	2.9	5.0
	1-1/2	21.0	6.0	4.3	51.0	48.8	50.1	41.8	3.3	5.0
	2	21.0	6.0	4.3	51.88	48.8	50.8	41.8	4.0	5.0
	3	21.0	6.0	4.3	51.88	49.1	52.1	41.8	6.1	7.3
8620	3/4	11.0	7.5	5.3	32.1	29.7	30.1	21.8	1.9	5.0
	1	11.0	7.5	5.3	32.1	29.8	30.4	21.8	2.5	5.0
	1-1/4	11.0	7.5	5.3	32.1	29.8	30.7	21.8	2.9	5.0
	1-1/2	11.0	7.5	5.6	32.1	29.8	30.1	21.8	3.3	5.0
	2	11.0	7.5	5.8	32.1	29.8	31.8	21.8	4.0	5.0
	3	11.0	7.5	6.8	32.4	30.3	33.2	21.8	6.1	7.3
8630	3/4	16.0	7.5	5.3	42.1	39.7	40.1	31.8	1.9	5.0
	1	16.0	7.5	5.3	42.1	39.8	40.4	31.8	2.5	5.0
	1-1/4	16.0	7.5	5.3	42.1	39.8	40.7	31.8	2.9	5.0
	1-1/2	16.0	7.5	5.6	42.1	39.8	40.1	31.8	3.3	5.0
	2	16.0	7.5	5.8	42.1	39.8	41.8	31.8	4.0	5.0
	3	16.0	7.5	6.8	42.4	40.3	43.2	31.8	6.1	7.3
8640	3/4	21.0	7.5	5.3	52.1	49.7	50.1	41.8	1.9	5.0
	1	21.0	7.5	5.3	52.1	49.8	50.4	41.8	2.5	5.0
	1-1/4	21.0	7.5	5.3	52.1	49.8	50.7	41.8	2.9	5.0
	1-1/2	21.0	7.5	5.6	52.1	49.8	50.1	41.8	3.3	5.0
	2	21.0	7.5	5.8	52.1	49.8	51.8	41.8	4.0	5.0
	3	21.0	7.5	6.8	52.4	50.3	53.2	41.8	6.1	7.3

R **Dimensions for Models 12-24 (IN)**

STYLE 1

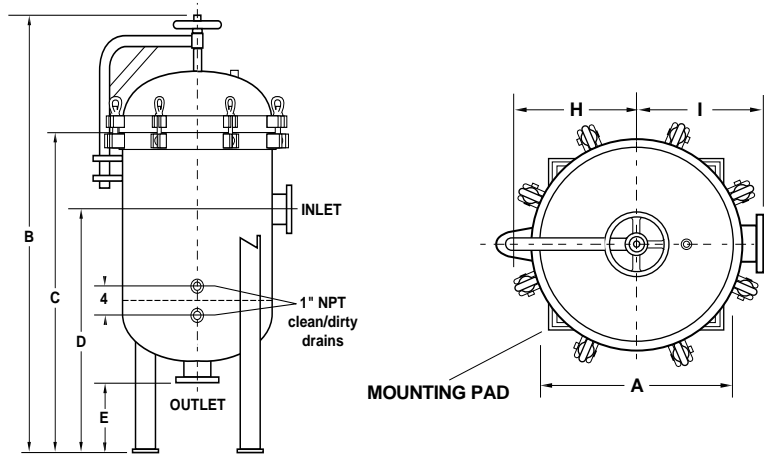

STYLE 2

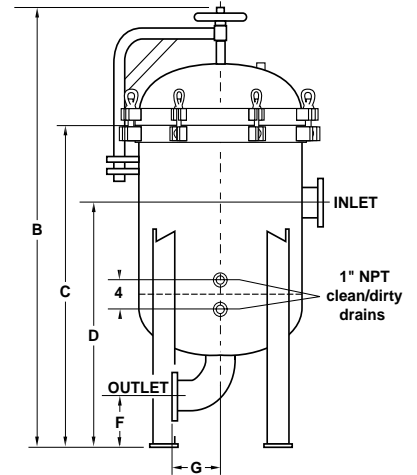

Model No.	No. of Cart.	Pipe Length	Pipe Size	STYLE 1					STYLE 2					Empty Weight (lbs)	Total Volume (cu. ft.)		
				A	B	C	D	E	B	C	D	F	G			H	I
12	12	20	2	12.0	59.1	43.1	33.1	12.0	50.6	34.6	24.6	4.5	5.5	9.3	10.0	370	2.2
			3						52.9	36.9	26.9	5.3	7.3			385	
			4						55.1	39.1	29.1	6.0	9.0			410	
		30	2	12.0	69.1	53.1	38.1	12.0	60.6	44.6	29.6	4.5	5.5	9.3	10.0	395	2.9
			3						62.9	46.9	31.9	5.3	7.3			410	
			4						65.1	49.1	34.1	6.0	9.0			425	
		40	2	12.0	79.1	63.1	43.1	12.0	70.6	54.6	34.6	4.5	5.5	9.3	10.0	420	3.7
			3						72.9	56.9	36.9	5.3	7.3			435	
			4						75.1	59.1	39.1	6.0	9.0			455	
16	20	20	2	16.0	61.1	44.1	34.1	12.0	52.6	35.6	25.6	4.5	5.5	10.9	12.0	450	3.6
			3						54.9	37.9	27.9	5.3	7.3			465	
			4						57.1	40.1	30.1	6.0	9.0			480	
		30	2	16.0	71.1	54.1	39.1	12.0	62.6	45.6	30.6	4.5	5.5	10.9	12.0	475	4.8
			3						64.9	47.9	32.9	5.3	7.3			495	
			4						67.1	50.1	35.1	6.0	9.0			510	
		40	2	16.0	81.1	64.1	44.1	12.0	72.6	55.6	35.6	4.5	5.5	10.9	12.0	505	5.9
			3						74.9	57.9	37.9	5.3	7.3			520	
			4						77.1	60.1	40.1	6.0	9.0			540	

Dimensions are reference only and should not be used for hard plumbing. Consult factory for certified drawings.

R **Dimensions for Models 12-24 (IN) Cont.**

Model No.	No. of Cart.	Cart. Length	Pipe Size	STYLE 1					STYLE 2					Empty Weight (lbs)	Total Volume (cu. ft.)								
				A	B	C	D	E	B	C	D	F	G			H	I						
18	27	20	2	18.0	62.1	44.6	34.6	12.0	53.6	36.1	26.1	4.5	5.5	11.9	13.0	480	4.7						
			3															55.9	38.4	28.4	5.3	7.3	500
			4															58.1	40.6	30.6	6.0	9.0	515
		30	2	18.0	72.1	54.6	39.6	12.0	63.6	46.1	31.1	4.5	5.5	11.9	13.0	515	6.1						
			3															65.9	48.4	33.4	5.3	7.3	530
			4															68.1	50.6	35.6	6.0	9.0	550
		40	2	18.0	82.1	64.6	44.6	12.0	73.6	56.1	36.1	4.5	5.5	11.9	13.0	550	7.6						
			3															75.9	58.4	38.4	5.3	7.3	565
			4															78.1	60.6	40.6	6.0	9.0	580
22	40	20	2	22.0	64.1	45.6	35.6	12.0	55.6	37.1	27.1	4.5	5.5	13.9	15.0	615	7.3						
			3															57.9	39.4	29.4	5.3	7.3	630
			4															60.1	41.6	31.6	6.0	9.0	645
		30	2	22.0	74.1	55.6	40.6	12.0	65.6	47.1	32.1	4.5	5.5	13.9	15.0	655	9.5						
			3															67.9	49.4	34.4	5.3	7.3	670
			4															70.1	51.6	36.6	6.0	9.0	690
		40	2	22.0	84.1	65.6	45.6	12.0	75.6	57.1	37.1	4.5	5.5	13.9	15.0	695	11.7						
			3															77.9	59.4	39.4	5.3	7.3	710
			4															80.1	61.6	41.6	6.0	9.0	730
		6	2	84.1	65.6	45.6	7.0	12.5	84.1	65.6	45.6	7.0	12.5	770	770	770	770						
			3															74.1	55.6	40.6	7.0	12.5	730
			6															74.1	55.6	40.6	7.0	12.5	730
24	52	20	2	24.0	65.1	46.1	36.1	12.0	56.6	37.6	27.6	4.5	5.5	14.9	16.0	665	8.8						
			3															58.9	39.9	29.9	5.3	7.3	680
			4															61.1	42.1	32.1	6.0	9.0	700
		30	2	24.0	75.1	56.1	41.1	12.0	66.6	47.6	32.6	4.5	5.5	14.9	16.0	710	11.4						
			3															68.9	49.9	34.9	5.3	7.3	725
			4															71.1	52.1	37.1	6.0	9.0	740
		6	2	75.1	56.1	41.1	7.0	12.5	75.1	56.1	41.1	7.0	12.5	790	790	790	790						
			3															71.1	52.1	37.1	6.0	9.0	740
			6															75.1	56.1	41.1	7.0	12.5	790
		40	2	24.0	85.1	66.1	46.1	12.0	76.6	57.6	37.6	4.5	5.5	14.9	16.0	750	14.0						
			3															78.9	59.9	39.9	5.3	7.3	770
			4															81.1	62.1	42.1	6.0	9.0	785
		6	2	85.1	66.1	46.1	7.0	12.5	85.1	66.1	46.1	7.0	12.5	830	830	830	830						
			3															81.1	62.1	42.1	6.0	9.0	785
			6															85.1	66.1	46.1	7.0	12.5	830



Dimensions for Models 30-48 (IN)

Model No.	No. of Cart.	Cart. Length	Pipe Size	STYLE 1					STYLE 2					Empty Weight (lbs)	Total Volume (cu. ft.)		
				A	B	C	D	E	B	C	D	F	G			H	I
30	82	20	2	30.0	68.1	47.6	37.6	12.0	59.6	39.1	29.1	4.5	5.5	17.9	19.0	955	14.5
			3						61.9	41.4	31.4	5.3	7.3	970			
			4						64.1	43.6	33.6	6.0	9.0	990			
			6						68.1	47.6	37.6	7.0	12.5	1035			
			8						72.4	51.9	41.9	8.3	16.0	1100			
		30	2	30.0	78.1	57.6	42.6	12.0	69.6	49.1	34.1	4.5	5.5	17.9	19.0	1030	18.6
			3						71.9	51.4	36.4	5.3	7.3	1045			
			4						74.1	53.6	38.6	6.0	9.0	1060			
			6						78.1	57.6	42.6	7.0	12.5	1110			
			8						82.4	61.9	46.9	8.3	16.0	1170			
		40	2	30.0	88.1	67.6	47.6	12.0	79.6	59.1	39.1	4.5	5.5	17.9	19.0	1100	22.7
			3						81.9	61.4	41.4	5.3	7.3	1120			
			4						84.1	63.6	43.6	6.0	9.0	1135			
			6						88.1	67.6	47.6	7.0	12.5	1180			
			8						92.4	71.9	51.9	8.3	16.0	1245			
36	116	20	2	36.0	71.1	49.1	39.1	12.0	62.6	40.6	30.6	4.5	5.5	20.9	22.0	1315	22.0
			3						64.9	42.9	32.9	5.3	7.3	1330			
			4						67.1	45.1	35.1	6.0	9.0	1350			
			6						71.1	49.1	39.1	7.0	12.5	1395			
			8						75.4	53.4	43.4	8.3	16.0	1460			
		30	2	36.0	81.1	59.1	44.1	12.0	72.6	50.6	35.6	4.5	5.5	20.9	22.0	1425	27.9
			3						74.9	52.9	37.9	5.3	7.3	1440			
			4						77.1	55.1	40.1	6.0	9.0	1460			
			6						81.1	59.1	44.1	7.0	12.5	1505			
			8						85.4	63.4	48.4	8.3	16.0	1570			
		40	2	36.0	91.1	69.1	49.1	12.0	82.6	60.6	40.6	4.5	5.5	20.9	22.0	1535	33.8
			3						84.9	62.9	42.9	5.3	7.3	1550			
			4						87.1	65.1	45.1	6.0	9.0	1570			
			6						91.1	69.1	49.1	7.0	12.5	1615			
			8						95.4	73.4	53.4	8.3	16.0	1680			
42	158	20	2	42.0	74.1	50.6	40.6	12.0	65.6	42.1	32.1	4.5	5.5	23.9	25.0	2030	31.6
			3						67.9	44.4	34.4	5.3	7.3	2045			
			4						70.1	46.6	36.6	6.0	9.0	2060			
			6						74.1	50.6	40.6	7.0	12.5	2110			



Dimensions for Models 30-48 (IN) Cont.

Model No.	No. of Cart.	Cart. Length	Pipe Size	STYLE 1					STYLE 2					Empty Weight (lbs)	Total Volume (cu. ft.)		
				A	B	C	D	E	B	C	D	F	G			H	I
			8						78.4	54.9	44.9	8.3	16.0		2170		
			10						82.6	59.1	49.1	9.5	19.0		2280		
			12						87.1	63.6	53.6	11.0	22.5		2415		
	30	2		42.0	84.1	60.6	45.6	12.0	75.6	52.1	37.1	4.5	5.5	23.9	25.0	2160	39.6
		3							77.9	54.4	39.4	5.3	7.3		2175		
		4							80.1	56.6	41.6	6.0	9.0		2195		
		6							84.1	60.6	45.6	7.0	12.5		2240		
		8							88.4	64.9	49.9	8.3	16.0		2305		
		10							92.6	69.1	54.1	9.5	19.0		2415		
		12							97.1	73.6	58.6	11.0	22.5		2550		
	40	2		42.0	94.1	70.6	50.6	12.0	85.6	62.1	42.1	4.5	5.5	23.9	25.0	2285	47.6
		3							87.9	64.4	44.4	5.3	7.3		2300		
		4							90.1	66.6	46.6	6.0	9.0		2320		
		6							94.1	70.6	50.6	7.0	12.5		2360		
		8							98.4	74.9	54.9	8.3	16.0		2430		
		10							102.6	79.1	59.1	9.5	19.0		2535		
		12							107.1	83.6	63.6	11.0	22.5		2670		
48	205	20	2	48.0	77.1	52.1	42.1	12.0	68.6	44.1	34.1	4.5	5.5	26.9	28.0	2510	43.2
			3						70.9	46.4	36.4	5.3	7.3		2520		
			4						73.1	48.6	38.6	6.0	9.0		2540		
			6						77.1	52.6	42.6	7.0	12.5		2585		
			8						81.4	56.9	46.9	8.3	16.0		2650		
			10						85.6	61.1	51.1	9.5	19.0		2760		
			12						90.1	65.6	55.6	11.0	22.5		2895		
	30	2		48.0	87.1	62.1	47.1	12.0	78.6	54.1	39.1	4.5	5.5	26.9	28.0	2655	53.7
		3							80.9	56.4	41.4	5.3	7.3		2670		
		4							83.1	58.6	43.6	6.0	9.0		2685		
		6							87.1	62.6	47.6	7.0	12.5		2730		
		8							91.4	66.9	51.9	8.3	16.0		2800		
		10							95.6	71.1	56.1	9.5	19.0		2905		
		12							100.1	75.6	60.6	11.0	22.5		3040		
	40	2		48.0	97.1	72.1	52.1	12.0	88.6	64.1	44.1	4.5	5.5	26.9	28.0	2800	64.1
		3							90.9	66.4	46.4	5.3	7.3		2815		
		4							93.1	68.6	48.6	6.0	9.0		2830		
		6							97.1	72.6	52.6	7.0	12.5		2880		
		8							101.4	76.9	56.9	8.3	16.0		2945		
		10							105.6	81.1	61.1	9.5	19.0		3050		
		12							110.1	85.6	65.6	11.0	22.5		3180		



How To Order

Build an ordering code as shown in the example.
Each available only on the model sizes highlighted in the colored blocks preceding its description

Key To Blocks:

4	6	8	12
4	6	8	12
4	6	8	12
4	6	8	12

= Model 4
= Model 6
= Model 8
= Model 12 etc.

Example: HOUSING **245230-4F-1-150-S-B-DOE-VP-C** OPTION

MODEL NO.
= 4
= 6
= 8
= 12
= 16
= 18
= 22
= 24
= 30
= 36
= 42
= 48

NUMBER OF CARTRIDGES¹
(Around) Cartridges
= 1
= 3
= 6
= 12
= 20
= 27
= 40
= 52
= 82
= 116
= 158
= 205

CARTRIDGE LENGTH¹
10-in. = 10
20-in. = 20
30-in. = 30
40-in. = 40

PIPE SIZE NPT (female)
3/4-in. = 3/4P
1-in. = 1P
1-1/4-in. = 1-1/4P
1-1/2-in. = 1-1/2P
2-in. = 2P
3-in. = 3P

FLANGED¹
3/4-in. = 3/4F
1-in. = 1F
1-1/4-in. = 1-1/4F
1-1/2-in. = 1-1/2F
2-in. = 2F
3-in. = 3F
4-in. = 4F
6-in. = 6F
8-in. = 8F
10-in. = 10F
12-in. = 12F

ASME CODE STAMP
C = Code

CARTRIDGE SEALING METHOD
VP = V Post and Spring Seal
TP = Threaded Post
For other styles, consult factory

CARTRIDGE DESIGN¹
DOE = Double-Open End
SOE = Single-Open End
222 = Double O-Ring
226 = Bayonet Lock (Pall)

COVER SEAL
B = Buna N
E = Ethylene Propylene
V = Viton®
TEV = Teflon® Encapsulated Viton®
TSW = Teflon® (solid white)

HOUSING MATERIAL²
C = Carbon Steel
S = 304 Stainless Steel
S316 = 316 Stainless Steel

PRESSURE RATING³
150 = 150 psi (NPT or flanged)
300 = 300 psi (NPT or flanged)

PIPING STYLE²
1 = Side Inlet, Bottom Outlet
2 = In-line, Inlet-high, Outlet-low

1. Flanges provided with the housing match the pressure rating of the vessel. Housings rated 150 psi have 150 class flanges. Housings rated 300 psi have 300 class flanges. Other styles and classes are available. ANSI B1 6.5 Pressure-Temperature rating tables determine flange class for ASME code housings. Consult factory.
2. Consult factory for special options.
3. Higher pressure ratings available. Consult factory.
4. Filter cartridges are sold separately. See pages 134.

Pressure Drop Data
Cartridge filters are usually selected so that the clean pressure drop does not exceed 2 psi. Higher pressure drops may be tolerated when contaminant loading is low. The user must determine the appropriate cartridge for the application, and note the flow rate ΔP per cartridge as suggested by the media manufacturer.

Viscosity Factors

(H ₂ O)	CPS NUMBER								
	1	50	100	200	400	600	800	1000	2000
	.65	.85	1.00	1.10	1.20	1.40	1.50	1.60	1.80