

**ENGINEERING STANDARDS**

Rosedale Products, Inc.  
3730 West Liberty Road  
Ann Arbor, MI 48103

IOM  
7\_3\_2 Model 6 150 Cart  
Convert.wpd  
n:\iom\



Issue Date: 30DEC99  
Revision: A  
Revision Date: 30May2003

Specification No.  
**7.3.2**  
PAGE: 1 of 8

**INSTALLATION, OPERATION, & MAINTENANCE MANUAL**

# INSTALLATION, OPERATION AND MAINTENANCE MANUAL

ROSEDALE PRODUCTS, INC.



MODEL 6

BAG/CARTRIDGE CONVERTIBLE  
150/300 PSIG RATED FILTER UNIT

## Table of Contents

I.	Installation .....	2
II.	Operation .....	4
III.	Spare Parts List .....	6
IV.	Spare Parts Diagram .....	7

## ENGINEERING STANDARDS

Rosedale Products, Inc.  
3730 West Liberty Road  
Ann Arbor, MI 48103

IOM  
7\_3\_2 Model 6 150 Cart  
Convert.wpd  
n:\iom\



Issue Date: 30DEC99  
Revision: A  
Revision Date: 30May2003

Specification No.  
**7.3.2**  
PAGE: 2 of 8

### INSTALLATION, OPERATION, & MAINTENANCE MANUAL

#### I. Installation

Please remove all shipping and crating materials carefully. Be sure to remove the plugs from the inlet and outlet openings. Dispose of all crating materials safely.

The Model 6 Filter unit is capable of having several different piping variations based upon the outlet style of your unit. The inlet service line should be connected to the inlet flange or NPT coupling located near the top of the unit (above the basket level).

The outlet service line should be connected to the outlet flange or coupling, located near the middle or bottom of the unit depending upon the style of your unit (below basket level).

There are two 1/4" NPT ports on the shell and one 1/4" NPT port on the cover of the Model 6 Filter unit. These ports can remain plugged or used for pressure gauges or special fittings as your application requires.

There are (2) 3/4" NPT ports near the bottom of the vessel. If you use the vessel as a bag/basket system, either port can be used as a clean port. If you use the vessel as a cartridge system, the top port is a dirty port, and the bottom port is your clean port

Some installations require electrical grounding of all equipment, be sure to provide adequate grounding where necessary.

After completing installation be sure to double check connections for integrity. Your Model 6 Filter unit has been factory pressure tested leak free, therefore, any seepage problems usually occur from improper installation connections.

#### FOR BASKET AND BAG FILTER UNITS

You are now ready to install the filter basket and bag (if applicable). Remove cover by loosening the cover eye nuts. The eye nuts in the slotted corners should be loosened sufficiently to swing free. Loosen the third eye nut sufficiently to allow the top cover and closure assembly to swing away from the top of the unit.

If your application requires a basket seal, insert the basket seal under the basket flange. Refer to Figure 1 in the Spare Parts Diagram for installation position of your seal.

Place the basket into the filter housing, make sure the basket flange is firmly seated into the basket collar.

Insert bag into the bag basket making sure filter bag ring is firmly seated inside the basket flange. For best results, be sure filter bag is installed fully extended to the bottom of the basket.

Before replacing cover assembly, inspect cover seal gasket (replacing as necessary). Close cover and alternately tighten the three clamp assemblies evenly to ensure a leak proof seal between the cover and housing body. Torque closure assemblies to a minimum of 60-90<sup>ft-lbs</sup>. Higher torque may be required depending on your application and filter condition.

## ENGINEERING STANDARDS

Rosedale Products, Inc.  
3730 West Liberty Road  
Ann Arbor, MI 48103

IOM  
7\_3\_2 Model 6 150 Cart  
Convert.wpd  
n:\iom\



Issue Date: 30DEC99  
Revision: A  
Revision Date: 30May2003

Specification No.  
**7.3.2**  
PAGE: 3 of 8

## INSTALLATION, OPERATION, & MAINTENANCE MANUAL

### FOR CARTRIDGE FILTER UNITS

You are now ready to install the filter cartridge units. Remove cover by loosening the cover eyenuts. The eyenuts in the slotted corners should be loosened sufficiently to swing free. Loosen the third eyenut sufficiently to allow the top cover and closure assembly to swing away from the top of the unit.

The next step is to install the cartridge units. Cartridge guide posts are provided with your housing to allow the use of 10" sections of cartridge and to aid in the proper seating of the cartridge. Insert your cartridges on these guide posts. Install the spring retainer cups onto each cartridge to hold your cartridges firmly in place when the cover is closed to prevent liquid from passing by unfiltered.

Before replacing cover assembly, inspect cover seal gasket (replacing as necessary). Close cover and alternately tighten the three clamp assemblies evenly to ensure a leak proof seal between the cover and housing body. Torque closure assemblies to a minimum of 60-90<sup>ft-lbs</sup>. Higher torque may be required depending on your application and filter condition.

Your Rosedale Model 6 is now ready for operation!

## ENGINEERING STANDARDS

Rosedale Products, Inc.  
3730 West Liberty Road  
Ann Arbor, MI 48103

IOM  
7\_3\_2 Model 6 150 Cart  
Convert.wpd  
n:\iom\



Issue Date: 30DEC99  
Revision: A  
Revision Date: 30May2003

Specification No.  
**7.3.2**  
PAGE: 4 of 8

### INSTALLATION, OPERATION, & MAINTENANCE MANUAL

#### II. Operation

##### Filter System Start-Up Procedure:

Prior to turning on the flow to the inlet service, please make the following checks:

1. Check inside filter unit to be sure basket and filter bag (if applicable) or cartridge, are in housing and do not require cleaning or replacement. If necessary install a clean filter basket and bag or cartridges (if applicable).
2. Check that filter unit cover is securely fastened to housing. You are now ready to open the flow to the inlet service line. Slowly open the inlet service line approximately 25% of normal operational flow (open slowly as not to displace filter bag inside the housing). After filter unit is pressurized and vented, slowly open outlet service line unit valve until completely open. Complete opening of inlet service line until desired flow rate is reached.

Once the desired service flow has been established, the filter will operate efficiently until dirty. However, under no circumstances should more than *15 PSI Differential Pressure* through the filter be obtained. Operating the filter unit with a high differential may cause filter bags to rupture or cause cartridges to collapse resulting in damage to filter system and downstream equipment.

To prevent excessive drop through the filter unit, regular inspection of the filter media is required. Monitoring of differential pressure through the housing can be utilized as a means of determining whether or not the filter media needs cleaning or replacement.

When it becomes necessary to clean or replace filter media, follow the procedure outlined below:

1. First close the flow from the inlet service line.
2. Close the flow to the outlet service line. (In some applications closing flow to outlet is not required.)
3. Relieve the pressure from the filter unit.

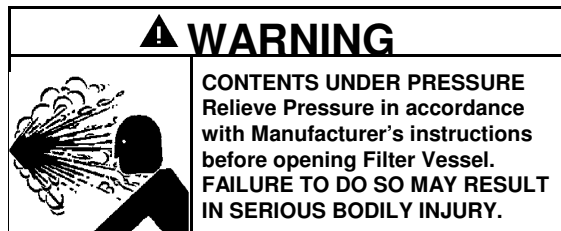

4. Drain housing sufficiently to access filter basket or cartridges.
5. Remove cover by loosening the cover eyenuts. The eyenuts in the slotted corners should be loosened sufficiently to swing free. Loosen the third eyenut sufficiently to allow the top cover and closure assembly to swing away from the top of the unit.

## ENGINEERING STANDARDS

Rosedale Products, Inc.  
3730 West Liberty Road  
Ann Arbor, MI 48103

IOM  
7\_3\_2 Model 6 150 Cart  
Convert.wpd  
n:\iom\



Issue Date: 30DEC99  
Revision: A  
Revision Date: 30May2003

Specification No.  
**7.3.2**  
PAGE: 5 of 8

### INSTALLATION, OPERATION, & MAINTENANCE MANUAL

6. Remove filter basket (or cartridges) and clean thoroughly, remove the filter bag (if applicable) and throw away. (Cleaning and reusing the filter bags or cartridges is not recommended.)
7. Remove debris and sludge from inside the inlet portion of housing to avoid interference with cover seal or flow of fluid being filtered.
8. Remove basket seal and inspect, replace if necessary. Clean basket seal groove and replace basket seal (see spare parts diagram for location of basket seal).
9. Install clean filter basket and filter bag (if applicable) or cartridges. Place the basket into the filter housing, make sure the basket flange is firmly seated into the basket collar. If applicable, insert bag into the bag basket making sure filter bag ring is firmly seated inside the basket flange. For best results, be sure filter bag is installed fully extended to the bottom of the basket.
10. Inspect cover gasket for cuts or other signs of failure and make sure it is properly seated.
11. Move cover back into position, and alternately tighten the three clamp assemblies evenly to ensure a leak proof seal between cover and housing body. Torque closure assemblies to a minimum of 60-90<sup>ft-lbs</sup>. Higher torque may be required depending on your application and filter condition.

Your Rosedale Model 6 Filter unit is now ready for operation. Refer to filter system start-up procedure.

## ENGINEERING STANDARDS

Rosedale Products, Inc.  
3730 West Liberty Road  
Ann Arbor, MI 48103

IOM  
7\_3\_2 Model 6 150 Cart  
Convert.wpd  
n:\iom\



Issue Date: 30DEC99  
Revision: A  
Revision Date: 30May2003

Specification No.  
**7.3.2**  
PAGE: 6 of 8

### INSTALLATION, OPERATION, & MAINTENANCE MANUAL

#### III. Spare Parts List

Your Rosedale Model 6 Filter unit will give you many years of reliable service provided periodic inspections are made of various components and replacement of worn parts are made promptly. The following is meant to be a recommended spare parts list, these parts are illustrated on the following page.

SPARE PARTS LIST			
Balloon	Description	Part Number	Time-Frame
1	Cover Seal	6150CG-*	as needed
2	Basket Seal	6BG-*	as needed
3	Cover	6*150	as needed
4	Eye Nut	6ENNI	as needed
5	Rod End	6RENI	as needed
6	Clevis Pin Assembly	6CPNI	as needed
7	Filter Bag	(See Order)	as needed
8	Filter Basket	(See Order)	as needed
9	Filter Cartridge	(See Order)	as needed
10	Spring Cup Retainer	C-5680	as needed
11	Guide Post	20" or 30"	as needed
12	Tripod Legs	6T18*S	as needed

\* Select Material Designation:

C=Carbon Steel	B=Buna N
S=304 Stainless Steel	E=Ethylene Propylene
S304L=304L Stainless Steel	V=Viton
S316=316 Stainless Steel	TEV=Teflon Encapsulated Viton
S316L=316L Stainless Steel	TSW=Teflon Solid White

# ENGINEERING STANDARDS

Rosedale Products, Inc.  
3730 West Liberty Road  
Ann Arbor, MI 48103

IOM  
7\_3\_2 Model 6 150 Cart  
Convert.wpd  
n:iom\



Issue Date: 30DEC99  
Revision: A  
Revision Date: 30May2003

Specification No.  
**7.3.2**  
PAGE: 7 of 8

## INSTALLATION, OPERATION, & MAINTENANCE MANUAL

### IV. Spare Parts Diagram

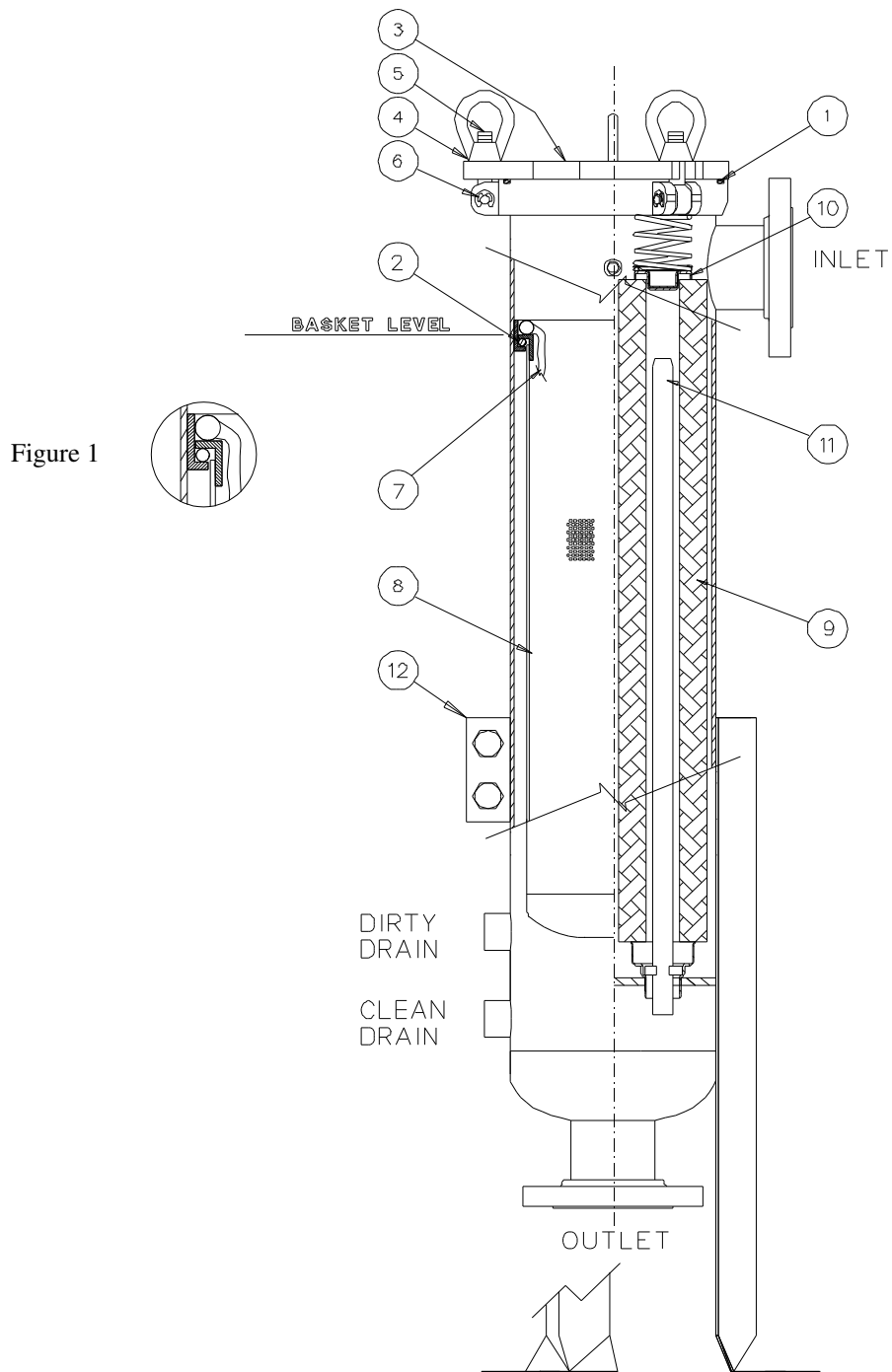

## ENGINEERING STANDARDS

Rosedale Products, Inc.  
3730 West Liberty Road  
Ann Arbor, MI 48103

IOM  
7\_3\_2 Model 6 150 Cart  
Convert.wpd  
n:iom\



Issue Date: 30DEC99  
Revision: A  
Revision Date: 30May2003

Specification No.  
**7.3.2**  
PAGE: 8 of 8

## INSTALLATION, OPERATION, & MAINTENANCE MANUAL

### Important Notice

**Warranty:** In the event any Rosedale Products, Inc. filtration product is found to be defective in material, workmanship, or not in conformance with any express warranty for a specific purpose, Rosedale's only obligation and your exclusive remedy, shall be to repair, replace or refund the purchase price of such parts or products upon timely notification thereof and substantiation that the product has been stored, maintained and used in accordance with Rosedale's written instructions.

**EXCLUSIONS TO WARRANTY:** THIS WARRANTY IS EXCLUSIVE AND IS IN LIEU OF ANY IMPLIED WARRANTY OF MERCHANTABILITY, FITNESS FOR A PARTICULAR PURPOSE OR OTHER WARRANTY OF QUALITY, EXCEPT OF TITLE AND AGAINST PATENT INFRINGEMENT.

**LIMITATION OF LIABILITY:** Except as provided above, Rosedale shall not be liable or responsible for any loss or damage, whether direct, indirect, incidental, special or consequential, arising out of sale, use or misuse of Rosedale filtration products, or the user's inability to use such products.

THE REMEDIES SET FORTH HEREIN ARE EXCLUSIVE.

**Rosedale Products, Inc.**  
3730 West Liberty Road  
Ann Arbor, MI 48103 USA  
734-665-8201  
800-821-5373  
Fax. 734-665-2214  
filters@rosedaleproducts.com  
<http://www.rosedaleproducts.com>