

**ENGINEERING STANDARDS**

Rosedale Products, Inc.  
3730 West Liberty Road  
Ann Arbor, MI 48103

IOM  
7\_3\_3 Model 6 Cart  
n:\iom\



Issue Date: 22MAR96  
Revision: B  
Revision Date: 30May2003

Specification No.  
**7.3.3**  
PAGE: 1 of 6

**INSTALLATION, OPERATION, & MAINTENANCE MANUAL**

# INSTALLATION, OPERATION AND MAINTENANCE MANUAL

ROSEDALE PRODUCTS, INC.



MODEL 6

150 & 300 PSIG RATED CARTRIDGE FILTER UNIT

## Table of Contents

I.	Installation .....	2
II.	Operation .....	3
III.	Spare Parts List .....	4
IV.	Spare Parts Diagram .....	5

## ENGINEERING STANDARDS

Rosedale Products, Inc.  
3730 West Liberty Road  
Ann Arbor, MI 48103

IOM  
7\_3\_3 Model 6 Cart  
n:\iom\



Issue Date: 22MAR96  
Revision: B  
Revision Date: 30May2003

Specification No.  
**7.3.3**  
PAGE: 2 of 6

### INSTALLATION, OPERATION, & MAINTENANCE MANUAL

#### I. Installation

Please remove all shipping and crating materials carefully. Be sure to remove the plugs from the inlet and outlet openings. Dispose of all crating materials safely.

The Model 6 Cartridge Filter unit is capable of having several different piping variations based upon the outlet style of your unit. The inlet service line should be connected to the inlet flange or NPT coupling located near the middle of unit (above cartridge plate).

The outlet service line should be connected to the outlet flange or coupling, located at the bottom of the unit (below cartridge plate).

Located just above the cartridge plate is a 3/4" NPT dirty side drain. Located just below the cartridge plate is another 3/4" NPT port, for clean side drainage.

There is a 1/4" NPT port on the cover of your Model 6 Filter Cartridge unit. This port can remain plugged or used for a pressure gauge, vent or special fitting as your application requires.

Some installations require electrical grounding of all equipment, be sure to provide adequate grounding where necessary.

After completing installation be sure to double check connections for integrity. Your Model 6 Cartridge Filter unit has been factory pressure tested leak free, therefore, any seepage problems usually occur from improper installation connections.

You are now ready to install the filter cartridge element. Remove cover by loosening the cover eye nuts. The eye nuts in the slotted corners should be loosened sufficiently to swing free. Loosen the third eye nut sufficiently to allow the top cover and closure assembly to swing away from the top of the unit.

The following procedures are for SOE or DOE cartridges utilizing V-Post installation. (Consult Cartridge Manufacturer for other installation applications.)

Insert centering V-post, tabbed end first, into cartridge cup located at the bottom of the unit. Place the element over centering V-post. Position the element over the center of the bottom retainer cup and press firmly into place. Place the retainer spring-cup assembly on top of the element and seat it against the cartridge. When the cover is closed, it will compress the spring assembly and seal the cartridge.

Before replacing cover assembly, inspect cover seal gasket (replacing as necessary). Close cover and alternately tighten the three clamp assemblies evenly to ensure a leak proof seal between the cover and housing body. Torque closure assemblies to a minimum of 60-90<sup>ft-lbs</sup>. Higher torque may be required depending on your application and filter condition.

Your Rosedale Model 6 Cartridge Filter unit is now ready for operation!

# ENGINEERING STANDARDS

Rosedale Products, Inc.  
3730 West Liberty Road  
Ann Arbor, MI 48103

IOM  
7\_3\_3 Model 6 Cart  
n:\iom\



Issue Date: 22MAR96  
Revision: B  
Revision Date: 30May2003

Specification No.  
**7.3.3**  
PAGE: 3 of 6

## INSTALLATION, OPERATION, & MAINTENANCE MANUAL

### II. Operation

#### Filter System Start-Up Procedure:

Prior to turning on the flow to the inlet service, please make the following checks:

1. Check inside filter unit to be sure cartridge element are in housing and do not require cleaning or replacement. If necessary install a clean cartridge element.
2. Check that filter unit cover is securely fastened to housing. You are now ready to open the flow to the inlet service line. Slowly open the inlet service line approximately 25% of normal operational flow (open slowly as not to displace cartridge element inside the housing). After filter unit is pressurized and vented, slowly open outlet service line unit valve until completely open. Complete opening of inlet service line until desired flow rate is reached.

Once the desired service flow has been established, the filter will operate efficiently until dirty. For Spiral Wound Cartridges it is recommended no more than *30 PSI Differential Pressure* through the filter be obtained. (Consult Cartridge Manufacturer for DP limits). Operating the filter unit with a high differential may cause cartridge elements to rupture and/or cause damage to filter system and downstream equipment.

To prevent excessive drop through the filter unit, regular inspection of the filter media is required. Monitoring of differential pressure through the housing can be utilized as a means of determining whether or not the filter media needs cleaning or replacement.

When it becomes necessary to clean or replace the cartridge element, follow the procedure outlined below:

1. First close the flow from the inlet service line.
2. Close the flow to the outlet service line. (In some applications closing flow to outlet is not required.)
3. Relieve the pressure from the filter unit.

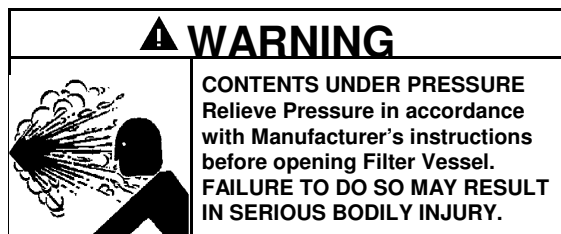

4. Drain housing sufficiently, use dirty drain port, to prevent bypass of unfiltered fluid. (Level to be below dirty drain and top of cartridge plate)
5. Remove cover by loosening the cover eyenuts. The eyenuts in the slotted corners should be loosened sufficiently to swing free. Loosen the third eyenut sufficiently to allow the top cover and closure assembly to swing away from the top of the unit.

# ENGINEERING STANDARDS

Rosedale Products, Inc.  
3730 West Liberty Road  
Ann Arbor, MI 48103

IOM  
7\_3\_3 Model 6 Cart  
n:iom\



Issue Date: 22MAR96  
Revision: B  
Revision Date: 30May2003

Specification No.  
**7.3.3**  
PAGE: 4 of 6

## INSTALLATION, OPERATION, & MAINTENANCE MANUAL

6. Remove cartridge element and throw away. (Note: Some cartridge elements are re-useable, and can be cleaned.)
7. Remove debris and sludge from inside the inlet portion of housing to avoid interference with cover seal or flow of fluid being filtered.
8. Install clean cartridge element. Be sure cartridge is seated on the bottom retainer cup, and top spring assembly is in place.
9. Inspect cover gasket for cuts or other signs of failure and make sure it is properly seated.
10. Move cover back into position, and alternately tighten the three clamp assemblies evenly to ensure a leak proof seal between cover and housing body. Torque closure assemblies to a minimum of 60-90<sup>ft</sup>-lbs. Higher torque may be required depending on your application and filter condition.

Your Rosedale Model 6 Cartridge Filter unit is now ready for operation. Refer to filter system start-up procedure.

### III. Spare Parts List

Your Rosedale Model 6 Cartridge Filter unit will give you many years of reliable service provided periodic inspections are made of various components and replacement of worn parts are made promptly. The following is meant to be a recommended spare parts list, these parts are illustrated on the following page.

SPARE PARTS LIST			
Balloon	Description	Part Number	Time-Frame
1	Cover Seal	6150CG*	as needed
2	Spring/Cup Ass'y	Spring Seal	as needed
3	Cover	6*150	as needed
4	Eye Nut	8ENNI	as needed
5	Rod End	8RENI	as needed
6	Clevis Pin Assembly	8CPNI	as needed
7	V-post	V-POST-#	as needed
8	Cartridge Element	(See Order)	as needed
9	Tripod Legs	6T18*S	as needed

\* Select Material Designation: C=Carbon Steel      B=Buna N  
S=304 Stainless Steel    E=Ethylene Propylene  
S316=316 Stainless Steel    V=Viton  
TEV=Teflon Encapsulated Viton  
TSW=Teflon Solid White

# Select Length: 10", 20", 30", or 40"

# ENGINEERING STANDARDS

Rosedale Products, Inc.  
3730 West Liberty Road  
Ann Arbor, MI 48103

IOM  
7\_3\_3 Model 6 Cart  
n:\iom\



Issue Date: 22MAR96  
Revision: B  
Revision Date: 30May2003

Specification No.  
**7.3.3**  
PAGE: 5 of 6

## INSTALLATION, OPERATION, & MAINTENANCE MANUAL

### IV. Spare Parts Diagram

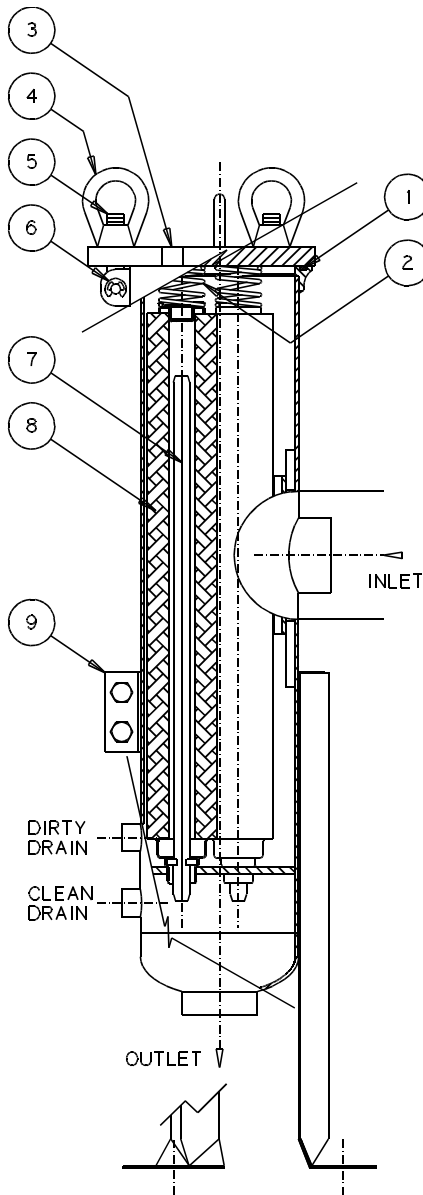

## ENGINEERING STANDARDS

Rosedale Products, Inc.  
3730 West Liberty Road  
Ann Arbor, MI 48103

IOM  
7\_3\_3 Model 6 Cart  
n:\iom\



Issue Date: 22MAR96  
Revision: B  
Revision Date: 30May2003

Specification No.  
**7.3.3**  
PAGE: 6 of 6

### INSTALLATION, OPERATION, & MAINTENANCE MANUAL

#### Important Notice

**Warranty:** In the event any Rosedale Products, Inc. filtration product is found to be defective in material, workmanship, or not in conformance with any express warranty for a specific purpose, Rosedale's only obligation and your exclusive remedy, shall be to repair, replace or refund the purchase price of such parts or products upon timely notification thereof and substantiation that the product has been stored, maintained and used in accordance with Rosedale's written instructions.

**EXCLUSIONS TO WARRANTY:** THIS WARRANTY IS EXCLUSIVE AND IS IN LIEU OF ANY IMPLIED WARRANTY OF MERCHANTABILITY, FITNESS FOR A PARTICULAR PURPOSE OR OTHER WARRANTY OF QUALITY, EXCEPT OF TITLE AND AGAINST PATENT INFRINGEMENT.

**LIMITATION OF LIABILITY:** Except as provided above, Rosedale shall not be liable or responsible for any loss or damage, whether direct, indirect, incidental, special or consequential, arising out of sale, use or misuse of Rosedale filtration products, or the user's inability to use such products.

THE REMEDIES SET FORTH HEREIN ARE EXCLUSIVE.

**Rosedale Products, Inc.**  
3730 West Liberty Road  
Ann Arbor, MI 48103 USA  
734-665-8201  
800-821-5373  
Fax. 734-665-2214  
filters@rosedaleproducts.com  
<http://www.rosedaleproducts.com>