

ENGINEERING STANDARDS

Rosedale Products, Inc.
3730 West Liberty Road
Ann Arbor, MI 48103

IOM
7_6_1_1 Clamshell
Supplement.wpd
n:iom\



Issue Date: 2NOV01
Revision: A
Revision Date: 30May2003

Specification No.
7.6.1.1
PAGE: 1 of 4

INSTALLATION, OPERATION, & MAINTENANCE MANUAL

CLAMSHELL COVER SUPPLEMENT (HYDRAULIC HAND PUMP ACTUATED) (supplement to Rosedale Products Specification No. 7.6.1)

ROSEDALE PRODUCTS, INC.



*Use in conjunction with the
MULTI-BASKET STRAINER & MULTI-BAG FILTER
Installation Operation and Maintenance Manual*

ENGINEERING STANDARDS

Rosedale Products, Inc.
3730 West Liberty Road
Ann Arbor, MI 48103

IOM
7_6_1_1 Clamshell
Supplement.wpd
n:iom\



Issue Date: 2NOV01
Revision: A
Revision Date: 30May2003

Specification No.
7.6.1.1
PAGE: 2 of 4

INSTALLATION, OPERATION, & MAINTENANCE MANUAL

Your Rosedale Products Filter Vessel has been equipped with a manual pump, Hydraulic actuated Clamshell type Cover to assist in the change out of the filter media.

Please follow all the installation instructions from the Installation Operation and Maintenance Manual Specification 7.6.1 for the Installation and Operation of you Rosedale Products Filter housing with the exception of opening/lifting the clamshell cover.

Opening the Clamshell Cover

(Only after the filter installation has been completed.)

1. Remove cover by loosening closure assemblies sufficiently to allow them to swing free.
2. Close valve on hand pump.
3. Pump handle until the cover raises to it's fully upright position and the yellow safety stop bar engages on the stop pin assembly.
4. Follow the installation instructions from the Installation Operation and Maintenance Manual Specification 7.6.1 for strainer baskets and/or filter bag replacement.
5. Before lowering the cover assembly, inspect cover seal (replace as necessary).
6. Close the cover by lifting and holding the yellow safety bar up from the safety pin assembly and opening the valve on the hand pump. Once the notch on the safety stop clears the stop pin, you no longer need to hold the yellow safety bar.
7. Once the cover has lowered completely, alternately tighten the closure assemblies evenly to ensure a leak proof seal between cover and housing body. The recommended torque value for the Multi-Basket Filter closure assemblies is 160-240^{Ft-Lbs}.

Please refer to the installation instructions from the Installation Operation and Maintenance Manual Specification 7.6.1 for the Operation of your Rosedale Products Inc., filter.

Adjustment

1. The cover Cylinder Assembly is factory set. If cylinder stroke adjustment is needed, adjustment shall be made with the turnbuckle assembly attached to the cylinder.
2. Cover closing speed is factory set. Adjustment to speed is accomplished by adjusting the flow control valve. Flow control valve has a Tamper Proof Pin which must be removed prior to adjustment and reinstalled after adjustment has been made.

⚠ WARNING	
	CONTENTS UNDER PRESSURE Relieve Pressure in accordance with Manufacturer's instructions before opening Filter Vessel. FAILURE TO DO SO MAY RESULT IN SERIOUS BODILY INJURY.

ENGINEERING STANDARDS

Rosedale Products, Inc.
3730 West Liberty Road
Ann Arbor, MI 48103

IOM
7_6_1_1 Clamshell
Supplement.wpd
n:\iom\



Issue Date: 2NOV01
Revision: A
Revision Date: 30May2003

Specification No.
7.6.1.1
PAGE: 3 of 4

INSTALLATION, OPERATION, & MAINTENANCE MANUAL

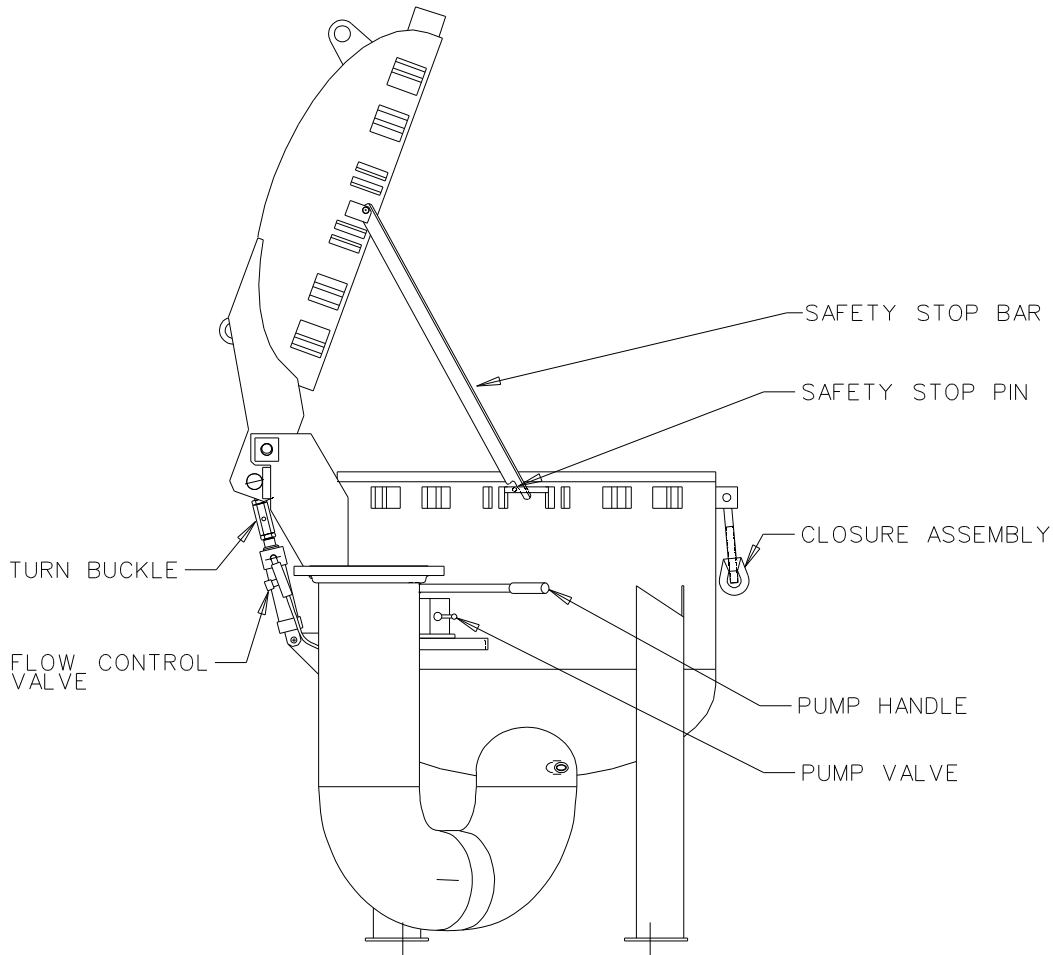

III. Spare Parts List (Clamshell Hydraulics)

SPARE PARTS LIST			
Item	Description	Part Number	
1	Pump P-51	15-9369	
2	Hose Assy.	15-8267	
3	Cylinder	15-8269	
4	Flow Control	15-8270	

Important Notice

Rosedale Engineering Standards are the property of Rosedale Products, Inc. A Rosedale standard or copy thereof shall not be distributed (except with express approval of Rosedale Products, Inc.) to any individual or firm beyond the intended recipient firm or individual. Firms of individuals acting contrary to the above may be subject to suit, ineligibility for continued or future employment, or removal from Rosedale's "Approved Manufacturers and Specialty Contractors List".

ENGINEERING STANDARDS

Rosedale Products, Inc.
3730 West Liberty Road
Ann Arbor, MI 48103

IOM
7_6_1_1 Clamshell
Supplement.wpd
n:iom\



Issue Date: 2NOV01
Revision: A
Revision Date: 30May2003

Specification No.
7.6.1.1
PAGE: 4 of 4

INSTALLATION, OPERATION, & MAINTENANCE MANUAL

Warranty: In the event any Rosedale Products, Inc. filtration product is found to be defective in material, workmanship, or not in conformance with any express warranty for a specific purpose, Rosedale's only obligation and your exclusive remedy, shall be to repair, replace or refund the purchase price of such parts or products upon timely notification thereof and substantiation that the product has been stored, maintained and used in accordance with Rosedale's written instructions.

EXCLUSIONS TO WARRANTY: THIS WARRANTY IS EXCLUSIVE AND IS IN LIEU OF ANY IMPLIED WARRANTY OF MERCHANTABILITY, FITNESS FOR A PARTICULAR PURPOSE OR OTHER WARRANTY OF QUALITY, EXCEPT OF TITLE AND AGAINST PATENT INFRINGEMENT.

LIMITATION OF LIABILITY: Except as provided above, Rosedale shall not be liable or responsible for any loss or damage, whether direct, indirect, incidental, special or consequential, arising out of sale, use or misuse of Rosedale filtration products, or the user's inability to use such products.

THE REMEDIES SET FORTH HEREIN ARE EXCLUSIVE.

Rosedale Products, Inc.
3730 West Liberty Road
Ann Arbor, MI 48103 USA
734-665-8201
800-821-5373
Fax. 734-665-2214
Email: filters@rosedaleproducts.com
<http://www.rosedaleproducts.com>