

ENGINEERING STANDARDS

Rosedale Products Inc.
3730 west liberty Road
Ann Arbor, MI 48103

IOM
7_4_27 Model CR8.DOC
N:\IOM\



Issue Date: 01MAY01
Revision: D
Revision Date: 24APR2015

Specification No.
7.4.27
Page 1 of 14

INSTALLATION, OPERATION AND MAINTENANCE MANUAL

INSTALLATION, OPERATION AND MAINTENANCE MANUAL

ROSEDALE PRODUCTS, INC.



MODEL CR8

CR8302F*100PP*-PB (STANDARD BAG FILTER)

CR81352F*100PP*-700 (STANDARD CARTRIDGE FILTER)

CR81352F*100PP*-700-PB (CONVERTIBLE FILTER)

Table of Contents

I.	Installation of Bag Filter Vessel (Diagram A).....	2
II.	Operation of Bag Filter Vessel.....	4
III.	Installation of Cartridge Filter Vessel (Diagram B)	6
IV.	Operation of Bag Filter Vessel.....	7
V.	Spare Parts List.....	9
VI.	Pressure-Temperature Rating Chart	10
VII.	Diagram A.....	11
VIII.	Diagram B.....	12

ENGINEERING STANDARDS

Rosedale Products Inc.
3730 west liberty Road
Ann Arbor, MI 48103

IOM
7_4_27 Model CR8.DOC
N:\IOM\



Issue Date: 01MAY01
Revision: D
Revision Date: 24APR2015

Specification No.
7.4.27
Page 2 of 14

INSTALLATION, OPERATION AND MAINTENANCE MANUAL

Introduction

Rosedale's Generation II Polypropylene Filter Vessels incorporate a unique one piece, seamless body that can handle flows to 100 gpm. It is rated to 100 psi @ 150 F (refer to pressure-temperature chart) and offer excellent resistance to corrosion. The vessel and cover are molded from a reinforced chemically coupled polypropylene homopolymer with a UV stabilizer making it suitable for outdoor use. The standard filter vessel is complete with one 1/4" Npt cover port, and two 1/4" Npt vessel body ports. When used as a bag filter, these two body ports can be used to monitor differential pressure. A convenient instrument mounting pad is provided for simple mounting of Rosedale standard instruments.

The Generation II Polypropylene Filter Vessel is designed to accept industry standard #2 size elements, including our standard bag line, bag size pleated cartridges, the Surfaceplus filter bag, and our latest series, the Platinum 700 line of absolute-rated cartridges.

Rosedale's Generation II Polypropylene Filter Vessels come complete with vent, gauge and drain plugs, hold-down if required, o-rings, and CPVC blind flange kit (w/ full face gasket, nuts & bolts).

I. Installation of Bag Filter Vessel (Diagram A)

Please remove all shipping and crating materials carefully. Be sure to remove the plugs from the inlet and outlet openings, gauge ports, etc. Dispose of desiccant package and all shipping materials safely.

The Model CR8 Filter unit is capable of having several different piping variations based upon the outlet style of your unit. The inlet service line should be connected to the inlet flange located near the top of the unit (above the basket level).

The outlet service line should be connected to the outlet flange, located near the middle or bottom of the unit depending upon the piping requirements of your system (below basket level).

Flanged Joints: As with all other thermoplastic piping components, the maximum non-shock operating pressure is a function of temperature. Please refer to the Pressure-Temperature Rating Chart in this manual. Remember to consider that when using thermoplastic piping components, the allowable pressure rating may be significantly less than allowed for the CR8 filter vessel.

When it is necessary to bolt plastic and metal flanges, use flat face metal flanges, not raised face, and use the recommended bolting torque of 20-30^{ft-lbs}. Flange gaskets should 1/8" thick, elastomeric full flat faced gasket with a hardness of 50 to 70 durometer.

The faces of thermoplastic flanges are tapered back away from the orifice area at a 1/2 to 1 degree pitch so that when the bolts are tightened the faces will be pulled together generating a force in the fluid path area to improve sealing.

ENGINEERING STANDARDS

Rosedale Products Inc.
3730 west liberty Road
Ann Arbor, MI 48103

IOM
7_4_27 Model CR8.DOC
N:\IOM\



Issue Date: 01MAY01
Revision: D
Revision Date: 24APR2015

Specification No.
7.4.27
Page 3 of 14

INSTALLATION, OPERATION AND MAINTENANCE MANUAL

CAUTION: As with all non-metallic flanges, extreme care should be taken when tightening the flange bolts. The maximum tightening torque is 30^{ft-lbs}. This is an industry standard for materials such as CPVC, PVC, PVDF and Polypropylene.

Flange Installation Tips:

1. Make sure that all the bolt holes of the mating flanges match up. It is not advisable to twist the flange and pipe to achieve this.
2. Use flat washers under bolt heads and nuts.
3. Insert all bolts (Lubricate bolts).
4. Make sure that the faces of the flanges mate snugly prior to tightening of the bolts.
5. The bolts on the plastic flanges should be tightened by pulling down the nuts diametrically opposite each other using a torque wrench. Complete tightening should be accomplished in stages. The final torque values are 20-30^{ft-lbs}. Uniform stress across the flange will prevent leaky gaskets.
6. The adjacent piping must be supported or anchored to eliminate excessive stress on the flange joint.

For side outlet configurations, an optional Adjustable Tripod Leg Assembly or PP mounting base is available for support of the filter unit. See spare parts list for ordering information.

There are two 1/4" NPT ports on the shell and one 1/4" NPT port on the cover of the Model CR8 Filter unit. These ports can remain plugged or used for pressure gauges, sample ports, vents or special fittings as your application requires.

Some installations require electrical grounding of all equipment, be sure to provide adequate grounding where necessary.

After completing installation be sure to double check connections for integrity. Your Model CR8 Filter unit has passed a stringent quality control inspection before leaving the factory.

You are now ready to install the filter basket and bag. Remove the cover by turning the cover counter-clockwise. Remove the bag hold-down device. Remove desiccant bag and other packing materials.

Insert bag into the bag basket making sure filter bag ring is firmly seated inside the basket sealing ring inside the vessel. For best results, be sure filter bag is installed fully extended to the bottom of the basket. Install bag hold-down device and verify the hold-down is adjusted correctly (see diagram).

ENGINEERING STANDARDS

Rosedale Products Inc.
3730 west liberty Road
Ann Arbor, MI 48103

IOM
7_4_27 Model CR8.DOC
N:\IOM\



Issue Date: 01MAY01
Revision: D
Revision Date: 24APR2015

Specification No.
7.4.27
Page 4 of 14

INSTALLATION, OPERATION AND MAINTENANCE MANUAL

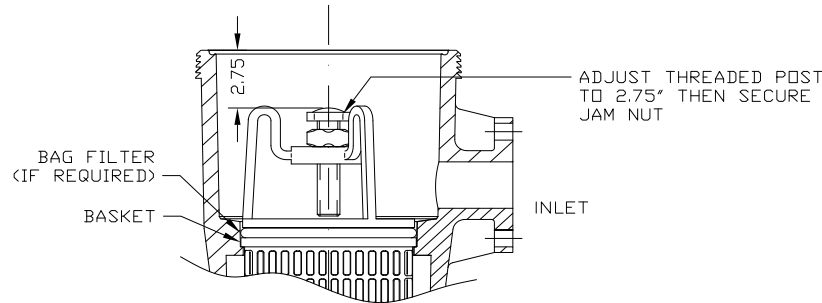

Hold-Down Adjustment Diagram

Before replacing cover, inspect cover seal gasket for damage, replacing as necessary. Install cover and turn clockwise till seated on the o-ring. Once initial contact with o-ring occurs, tighten approximately one half turn. The application of process fluid (to wet seal) or lubricant will make it easier to install cover for a sufficient seal. During the first several opening and closing cycles, there may be some chafing of the cover threads. This is normal, and will cease as threads work into each other.

Your Rosedale Model CR8 is now ready for operation!

II. Operation of Bag Filter Vessel.

Filter System Start-Up Procedure:

Prior to turning on the flow to the inlet service, please make the following checks:

1. Check inside filter unit to be sure basket and filter bag (if applicable) are in housing and do not require cleaning or replacement. If necessary install a clean filter basket and bag (if applicable).
2. Check that filter unit cover is securely fastened to housing. You are now ready to open the flow to the inlet service line. Slowly open the inlet service line approximately 25% of normal operational flow (open slowly as not to displace filter bag inside the housing). After filter unit is pressurized and vented, slowly open outlet service line unit valve until completely open. Complete opening of inlet service line until desired flow rate is reached.

ENGINEERING STANDARDS

Rosedale Products Inc.
3730 west liberty Road
Ann Arbor, MI 48103

IOM
7_4_27 Model CR8.DOC
N:\IOM\



Issue Date: 01MAY01
Revision: D
Revision Date: 24APR2015

Specification No.
7.4.27
Page 5 of 14

INSTALLATION, OPERATION AND MAINTENANCE MANUAL

Once the desired service flow has been established, the filter will operate efficiently until dirty. However, under no circumstances should more than *15 PSI Differential Pressure* through the filter be obtained. Operating the filter unit with a high differential may cause filter bags to rupture and/or cause damage to filter system and downstream equipment.

To prevent excessive drop through the filter unit, regular inspection of the filter media is required. Monitoring of differential pressure through the housing can be utilized as a means of determining whether or not the filter media needs cleaning or replacement.

When it becomes necessary to clean or replace filter media, follow the procedure outlined below:

1. First close the flow from the inlet service line.
2. Close the flow to the outlet service line. (In some applications closing flow to outlet is not required.)
3. Relieve the pressure from the filter unit.



4. Drain housing sufficiently to access filter basket.
5. Remove the cover by turning the cover counter-clockwise. Remove the bag hold-down device.
6. Remove filter bag and replace (if applicable) and throw away. (Cleaning and reusing the filter bag is not recommended.)
7. Remove debris and sludge from inside the inlet portion of housing to avoid interference with cover seal or flow of fluid being filtered.
8. Install new filter bag (if applicable). Place the basket into the filter housing, make sure the basket flange is fully seated into the basket collar in the vessel. If applicable, insert bag into the bag basket making sure filter bag ring is firmly seated inside the basket ring in the vessel. For best results, be sure filter bag is installed fully extended to the bottom of the basket.
10. Inspect cover gasket for cuts or other signs of failure and make sure it is properly seated.
11. Move cover back into position, Install cover by turning clockwise till seated on the o-ring. Once initial contact with o-ring occurs, tighten approximately one half turn. The application of process fluid (to wet seal) or lubricant will make it easier to install cover for a sufficient seal.

ENGINEERING STANDARDS

Rosedale Products Inc.
3730 west liberty Road
Ann Arbor, MI 48103

IOM
7_4_27 Model CR8.DOC
N:\IOM\



Issue Date: 01MAY01
Revision: D
Revision Date: 24APR2015

Specification No.
7.4.27
Page 6 of 14

INSTALLATION, OPERATION AND MAINTENANCE MANUAL

Your Rosedale Model CR8 Filter unit is now ready for operation. Refer to Filter System Start-up Procedure.

III. Installation of Cartridge Filter Vessel (Diagram B).

Please remove all shipping and crating materials carefully. Be sure to remove the plugs from the inlet and outlet openings, gauge ports, etc. Dispose of desiccant package and all shipping materials safely.

The Model CR8135 Filter unit is capable of having several different piping variations based upon the outlet style of your unit. The inlet service line should be connected to one of the inlet flanges located near the top of the unit on the shell (above the basket ring level).

The outlet service line should be connected to the outlet flange, located at the bottom of the unit.

An optional Adjustable Tripod Leg Assembly is available for support of the filter unit. See spare parts list for ordering information.

There are two 1/4" NPT ports on the shell and one 1/4" NPT port on the cover of the Model CR8 Filter unit. These ports can remain plugged or used for pressure gauges, sample ports, vents or special fittings as your application requires.

Some installations require electrical grounding of all equipment, be sure to provide adequate grounding where necessary.

After completing installation be sure to double check connections for integrity. Your Model CR8 Filter unit has passed a stringent quality control inspection before leaving the factory.

If you ordered a CR8-1-35 Cartridge Vessel, the *basket and hold-down* are **not** shipped with the product. The cartridge adapter (5-2241) will be installed with o-rings matching the cover seal. Both the Platinum 700 cartridge and cartridge pedestal use standard -226 size o-rings. If you've purchased the CR8 Filter Vessel as a bag filter, you'll need to install the optional cartridge pedestal. If you've purchased the CR-8 Filter Vessel as a convertible housing (capable of using a bag or Platinum series 700 cartridge). The cartridge pedestal (5-2241) will be installed with o-rings matching the cover seal.

You are now ready to install the Platinum Series 700 cartridge. Remove the cover by turning the cover counter-clockwise. Remove the bag hold-down device and bag if equipped. Remove desiccant bag and other packing materials. If not already installed, install the cartridge pedestal by wetting the three o-rings and inserting into the outlet nozzle as shown on attached drawing.

ENGINEERING STANDARDS

Rosedale Products Inc.
3730 west liberty Road
Ann Arbor, MI 48103

IOM
7_4_27 Model CR8.DOC
N:\IOM\



Issue Date: 01MAY01
Revision: D
Revision Date: 24APR2015

Specification No.
7.4.27
Page 7 of 14

INSTALLATION, OPERATION AND MAINTENANCE MANUAL

Insert the cartridge into the cartridge pedestal making sure the cartridge is fully seated into the pedestal. When properly installed, there will be an 1/8" clearance from the top of the 700 cartridge to the concave cover. The cover will function as a hold-down for the 700 cartridge.

Before replacing cover, inspect cover seal gasket for damage, replacing as necessary. Install cover and turn clockwise till seated on the o-ring. Once initial contact with o-ring occurs, tighten approximately one half turn. The application of process fluid (to wet seal) or lubricant will make it easier to install cover for a sufficient seal. During the first several opening and closing cycles, there may be some chafing of the cover threads. This is normal, and will cease as threads work into each other.

Your Rosedale Model CR8135 is now ready for operation!

ENGINEERING STANDARDS

Rosedale Products Inc.
3730 west liberty Road
Ann Arbor, MI 48103

IOM
7_4_27 Model CR8.DOC
N:\IOM\



Issue Date: 01MAY01
Revision: D
Revision Date: 24APR2015

Specification No.
7.4.27
Page 8 of 14

INSTALLATION, OPERATION AND MAINTENANCE MANUAL

IV. Operation of Cartridge Filter Vessel.

Filter System Start-Up Procedure:

Prior to turning on the flow to the inlet service, please make the following checks:

1. Check inside filter unit to be sure cartridge is in housing and does not require cleaning or replacement. If necessary install a cartridge filter.
2. Check that filter unit cover is securely fastened to housing. You are now ready to open the flow to the inlet service line. Slowly open the inlet service line approximately 25% of normal operational flow. After filter unit is pressurized and vented, slowly open outlet service line unit valve until completely open. Complete opening of inlet service line until desired flow rate is reached.

Once the desired service flow has been established, the filter will operate efficiently until dirty. However, under no circumstances should more than *25 PSI Differential Pressure* through the filter be obtained. Operating the filter unit with a high differential may cause filter cartridges to collapse and/or cause damage to filter system and downstream equipment.

To prevent excessive drop through the filter unit, regular inspection of the filter media is required. Monitoring of differential pressure through the housing can be utilized as a means of determining whether or not the filter media needs cleaning or replacement.

When it becomes necessary to clean or replace filter media, follow the procedure outlined below:

1. First close the flow from the inlet service line.
2. Close the flow to the outlet service line. (In some applications closing flow to outlet is not required.)
3. Relieve the pressure from the filter unit.



4. Drain vessel completely to access filter cartridge.
5. Remove the cover by turning the cover counter-clockwise.
6. Remove filter cartridge using integral handle and replace and throw away. (Cleaning and reusing the filter cartridge is not recommended.)

ENGINEERING STANDARDS

Rosedale Products Inc.
3730 west liberty Road
Ann Arbor, MI 48103

IOM
7_4_27 Model CR8.DOC
N:\IOM\



Issue Date: 01MAY01
Revision: D
Revision Date: 24APR2015

Specification No.
7.4.27
Page 9 of 14

INSTALLATION, OPERATION AND MAINTENANCE MANUAL

7. Remove debris and sludge from inside the inlet portion of housing to avoid interference with cover seal or flow of fluid being filtered.
8. Install new filter cartridge. Make sure the cartridge is fully seated into the cartridge pedestal.
10. Inspect cover gasket for cuts or other signs of failure and make sure it is properly seated.
11. Move cover back into position, Install cover by turning clockwise till seated on the o-ring. Once initial contact with o-ring occurs, tighten approximately one half turn. The application of process fluid (to wet seal) or lubricant will make it easier to install cover for a sufficient seal.

Your Rosedale Model CR8135 Filter unit is now ready for operation. Refer to Filter System Start-up Procedure.

ENGINEERING STANDARDS

Rosedale Products Inc.
3730 west liberty Road
Ann Arbor, MI 48103

IOM
7_4_27 Model CR8.DOC
N:\IOM\



Issue Date: 01MAY01
Revision: D
Revision Date: 24APR2015

Specification No.
7.4.27
Page 10 of 14

INSTALLATION, OPERATION AND MAINTENANCE MANUAL

V. Spare Parts List

Your Rosedale Model CR8 Filter unit will give you many years of reliable service provided periodic inspections are made of various components and replacement of worn parts are made promptly. See following spare parts list.

SPARE PARTS LIST				
Number	Description	P/N	Material	Time-Frame
1	Cover Seal	CR8CG-B	Buna	as needed
	Cover Seal	CR8CG-E	EPR	as needed
	Cover Seal	CR8CG-V	Viton	as needed
	Cover Seal	CR8CG-TEV	TEV	as needed
2	CR8 Cover	8-2004	PP, 10 % Glass filled, w/ UV	as needed
3	CR8 Vessel Body Only	M8-1002	PP 10 % Glass filled, w/ UV	as needed
4	CR8 Hold-Down Assy.	5-03246L	PP	as needed
5	CR8 Basket	B-2003	PP	as needed
6	1/4" NPT PP Plug	5-1817	PP	as needed
7	3/4" NPT PP Plug	5-1222	PP	as needed
8	Filter Bag	(See Order)	per application	as needed
9	Filter Cartridge	(See Order)	per application	as needed
10	Cover Tool	8-6642	Zinc Plate DI	as needed
11	1/4" PP Ball Valve	5-1829	PP w/ Viton Seats	as needed
12	3/4" PP Ball Valve	5-1831	PP w/ Viton Seats	as needed
13	Cartridge Pedestal	5-2241	PP	as needed
14	Cartridge/Pedestal O-ring	CR8PED-B	Buna	as needed
	Cartridge/Pedestal O-ring	CR8PED-E	EPR	as needed
	Cartridge/Pedestal O-ring	CR8PED-V	Viton	as needed
	Cartridge/Pedestal O-ring	CR8PED-T	TEV	as needed
15	Tripod Legs	CR8T28-304S	304 SS	as needed
	Tripod Legs	CR8T28-316S	316 SS	as needed
16	Flange Kit	CR8FLG-B	CPVC CL150 FF, Buna gasket, zinc plt. nuts/bolts	as needed
	Flange Kit	CR8FLG-E	CPVC CL150 FF, EPR gasket, zinc plt. nuts/bolts	as needed
	Flange Kit	CR8FLG-V	CPVC CL150 FF, Viton gasket, zinc plt. nuts/bolts	as needed
	Flange Kit	CR8FLG-T	CPVC CL150 FF, TSW gasket, zinc plt. nuts/bolts	as needed
17	PP Mounting Base Kit (not shown)	Consult Factory	PP, gasket, nuts, bolts, washers	as needed

PP=Polypropylene (Natural)

ENGINEERING STANDARDS

Rosedale Products Inc.
3730 west liberty Road
Ann Arbor, MI 48103

IOM
7_4_27 Model CR8.DOC
N:\IOM\



Issue Date: 01MAY01
Revision: D
Revision Date: 24APR2015

Specification No.
7.4.27
Page 11 of 14

INSTALLATION, OPERATION AND MAINTENANCE MANUAL

VI. Pressure-Temperature Rating Chart.

Warning: Rosedale does not recommend use of the CR8 Filter Vessel above the maximum pressure limits or outside the temperature range illustrated by the chart below.

In all installations, limiting impact reactions due to fluid shock (water hammer, etc.) is an important consideration for safe operation of the filter unit. This is especially important at temperatures below 70 F.

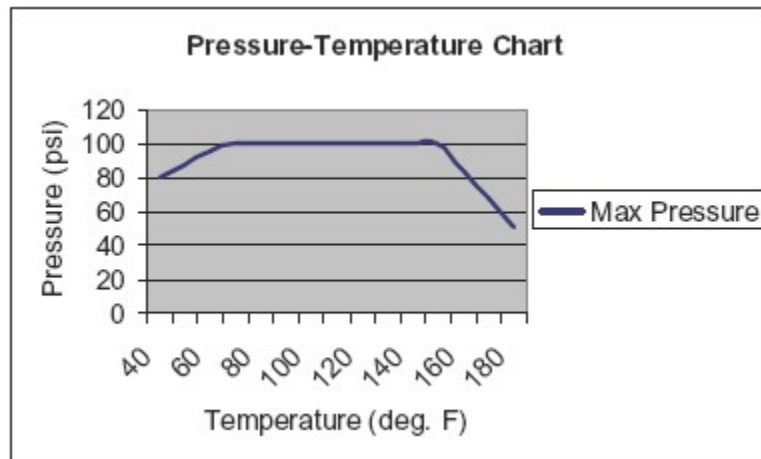

Special Notice

DO NOT USE THIS FILTER VESSEL PRODUCT WHEN ANY OPERATING TEMPERATURE CONDITION IS LESS THAN 40°F OR GREATER THAN 180°F.

Operating temperature conditions to consider when using the Rosedale CR8 filter vessel include, but are not limited to the following; operating temperatures extremes; operational upsets; autorefrigeration; atmospheric temperature; equipment temperature at start-up; process fluid temperature; seasonal environmental conditions; thermal process reactions; and any other sources of cooling or heating.

Because of the characteristics of the material of construction of the Rosedale CR8 Filter Vessel (glass filled polypropylene). Rosedale strongly recommends limiting loadings to the filter vessel such as cyclic and dynamic reactions due to pressure and thermal variations; seismic reactions; impact reactions due to fluid shock; temperature gradients and differential thermal expansion; abnormal pressure variations and superimposed static reaction from weight of attached equipment such as piping, internals, linings and insulation.

ENGINEERING STANDARDS

Rosedale Products Inc.
3730 west liberty Road
Ann Arbor, MI 48103

IOM
7_4_27 Model CR8.DOC
N:\IOM\



Issue Date: 01MAY01
Revision: D
Revision Date: 24APR2015

Specification No.
7.4.27
Page 12 of 14

INSTALLATION, OPERATION AND MAINTENANCE MANUAL

VII. Diagram A

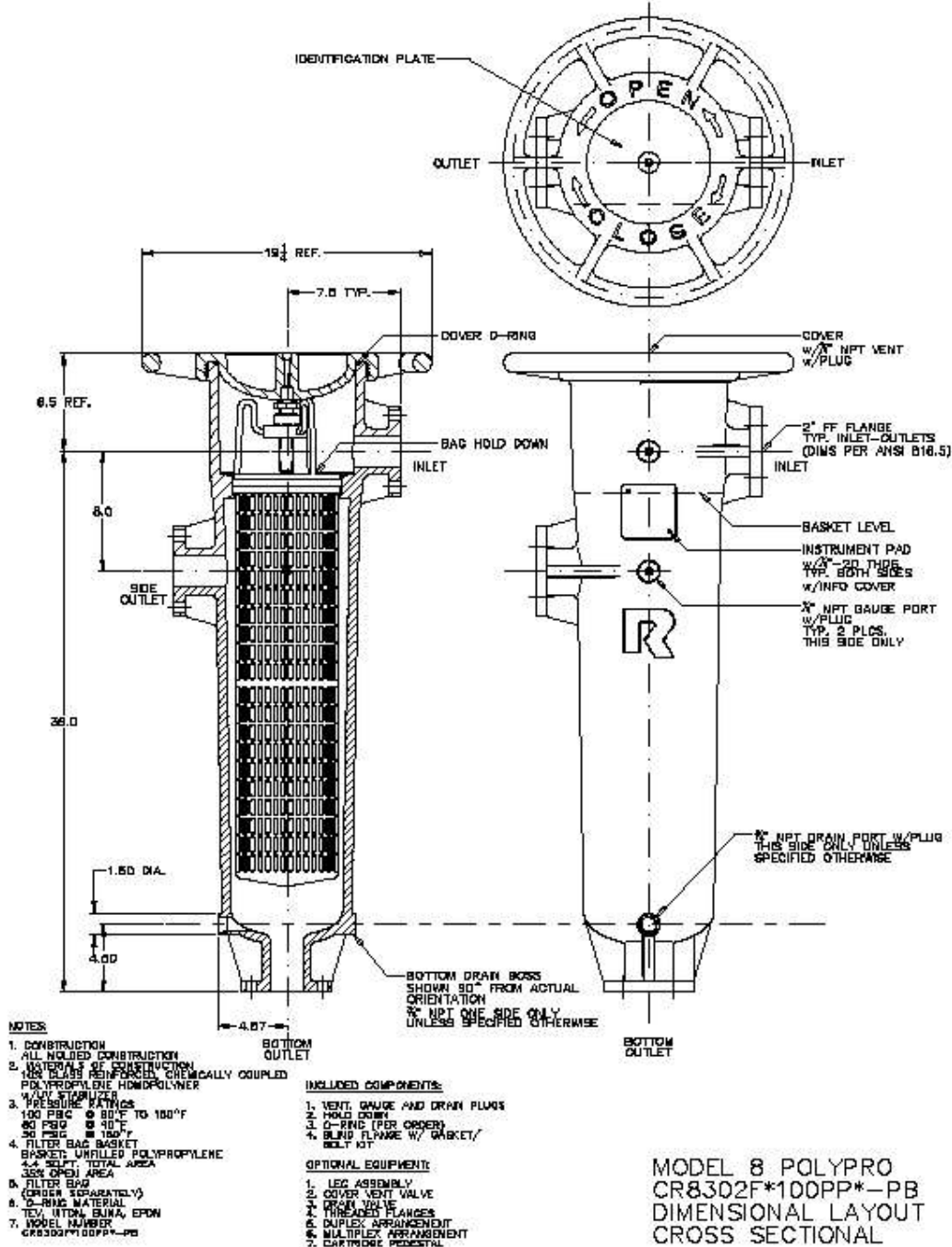

ENGINEERING STANDARDS

Rosedale Products Inc.
3730 west liberty Road
Ann Arbor, MI 48103

IOM
7_4_27 Model CR8.DOC
N:\IOM\



Issue Date: 01MAY01
Revision: D
Revision Date: 24APR2015

Specification No.
7.4.27
Page 13 of 14

INSTALLATION, OPERATION AND MAINTENANCE MANUAL

VIII. Diagram B

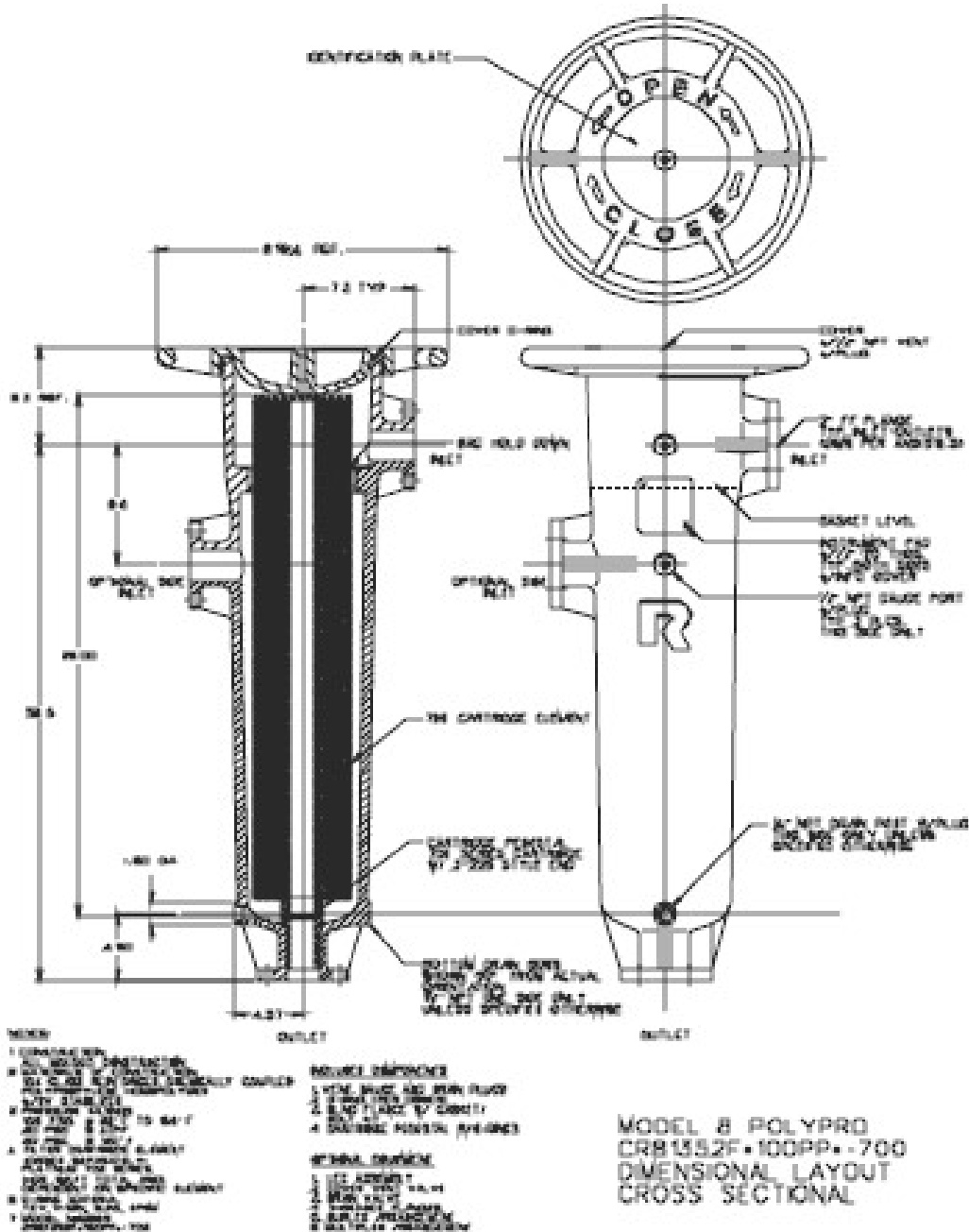

ENGINEERING STANDARDS

Rosedale Products Inc.
3730 west liberty Road
Ann Arbor, MI 48103

IOM
7_4_27 Model CR8.DOC
N:\IOM\



Issue Date: 01MAY01
Revision: D
Revision Date: 24APR2015

Specification No.
7.4.27
Page 14 of 14

INSTALLATION, OPERATION AND MAINTENANCE MANUAL

Important Notice

Warranty: In the event any Rosedale Products, Inc. filtration product is found to be defective in material, workmanship, or not in conformance with any express warranty for a specific purpose, Rosedale's only obligation and your exclusive remedy, shall be to repair, replace or refund the purchase price of such parts or products upon timely notification thereof and substantiation that the product has been stored, maintained and used in accordance with Rosedale's written instructions.

EXCLUSIONS TO WARRANTY: THIS WARRANTY IS EXCLUSIVE AND IS IN LIEU OF ANY IMPLIED WARRANTY OF MERCHANTABILITY, FITNESS FOR A PARTICULAR PURPOSE OR OTHER WARRANTY OF QUALITY, EXCEPT OF TITLE AND AGAINST PATENT INFRINGEMENT.

LIMITATION OF LIABILITY: Except as provided above, Rosedale shall not be liable or responsible for any loss or damage, whether direct, indirect, incidental, special or consequential, arising out of sale, use or misuse of Rosedale filtration products, or the user's inability to use such products.

THE REMEDIES SET FORTH HEREIN ARE EXCLUSIVE.

Rosedale Products, Inc.
3730 West Liberty Road
Ann Arbor, MI 48103 USA
734-665-8201
800-821-5373
Fax. 734-665-2214
filters@rosedaleproducts.com
<http://www.rosedaleproducts.com>