

R Portable Filter Cart For Coolants and Metalworking Fluids

Rugged, Versatile,
and On the Move ...

This versatile portable filter cart (PFC), is easily movable from machine to machine, holding tank to reservoir, or drum to tank. These two wheel hand truck systems provide a means for pre-filtering and transferring fluids. They are most effective controlling particulate problems before they cause damage to critical production equipment. Rosedale's PFCs' high-flow, industrial quality centrifugal pumps transfer fluids quickly and economically.

Applications

Portable filter systems can be used with coolants and other fluids with viscosities of 300 ssu or less that are compatible with aluminum and steel. Most new fluids are unfit for use in hydraulic and lube systems. Contamination enters the fluid during processing, mixing, handling and storage. Solid particulate may be present in unacceptable levels. Portable filter carts are the ideal means of pre-filtering and transferring these fluids. With a 1/2 horsepower motor and bag filter housing, this two wheel hand truck system is used for fluids with viscosities of 300 ssu or less.

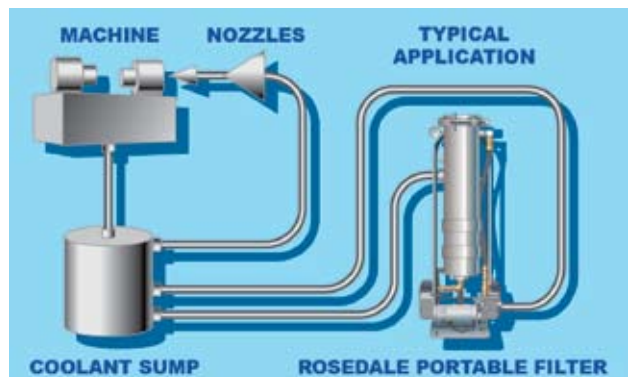

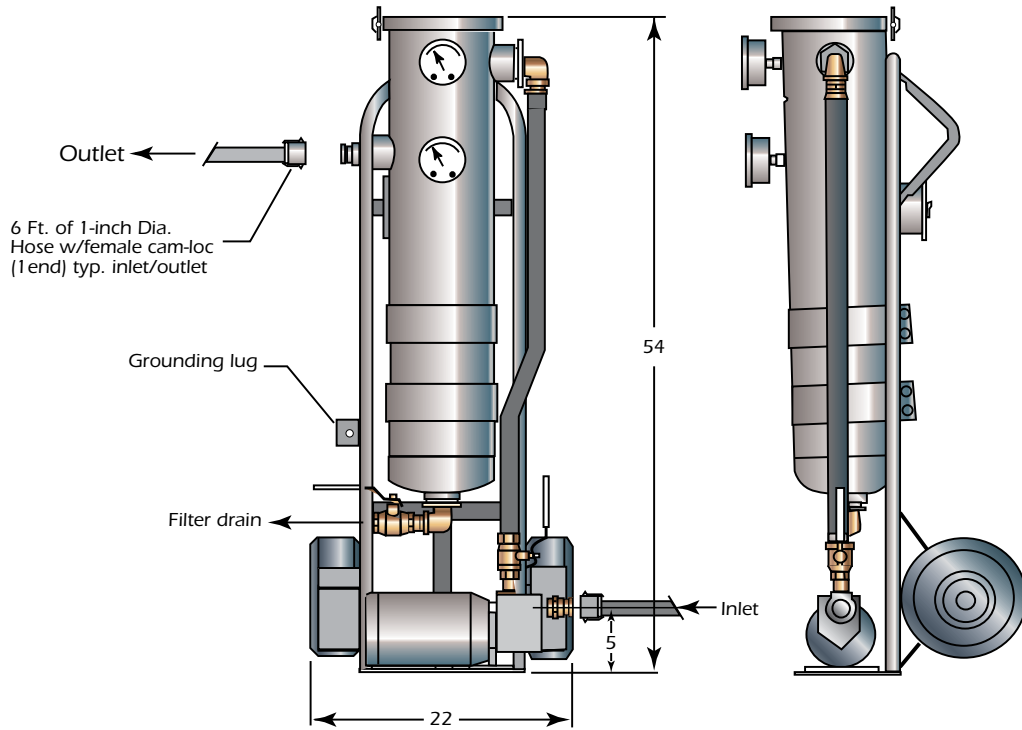

1" Self-Priming Centrifugal Pump Specs						
GPH of Water at Total Feet of Head*					Max. Head	
10ft.	20ft.	30ft.	40ft.	50ft.	Ft.	PSI
2280	1920	1440	900	360	57	25

(*) Flow rate based on 1" pipe; flow rate and pressure will decrease with smaller pipe and/or base.

Portable Filter Cart – Ordering Code Example:			
	Housing		Options
Pre-Selected Example Code:	PFC8	30 1P 125	C B PB
Model No. =	PFC8		
Housing Size	30 inch	= 30	
Pipe Size	1 inch female NPT	= 1P	
Pressure Rating	125 psi	= 125	
Housing Material	Carbon Steel	= C	
Cover Seal	Buna N	= B	
Basket Type	30 inch	= PB	

Model 8 Suggested Bags — General Uses					
	PE	5	P	12	S
Fiber Rating					
Felt, Polyester	= PE				
Micron Rating (grade)*					
General Use	= 5, 25				
Fine	= BB-12				
Very Fine	= BB-10				
Ultra Fine	= BB-1				
Bag Finish					
None	=		P		
Bag Size and Dimensions					
8-3/8 x 32	=		12		
Bag Style					
Carbon Steel Plated Ring	=				S